

MODEL DISCOVERER 7-1

hy-gain

40-Meter 1-Element
Dipole Antenna

ORDER NO. 371S

NOTICE

All rights in this publication are reserved. No part of the publication may be reproduced in any manner whatsoever without the expressed written permission of Hy-Gain.

TABLE OF CONTENTS

CHAPTER I

General Description.....	1
Specifications	1

CHAPTER 2

Preparation for Assembly	3
--------------------------------	---

CHAPTER 3

Assembly of the Boom-to-Mast Brackets and Boom.....	5
Assembly of the Driven Element	6
Linear-Loading Wire Assembly	9
Final Assembly	11

CHAPTER 4

Adjustment for Operation Between 7.3 and 10.5 MHz.	13
Installation	14
Service Information	14
Parts List.....	15

LIST OF ILLUSTRATIONS

Figure		Page
1	Boom-to-Mast Bracket	5
2	Assembly of the Element-to-Boom Brackets	6
3	Assembly of the Driven Element	7
4	Compression Clamps	8
5	DE5 Section Dimension Chart	9
6	Installing "Hairpins" on Driven Element	10
7	"Hairpin" Attachment Near 40 Meter Insulator	11
8	Identification of Linear-Loading Wires (LLW)	12
9	Adjustment of LLW Shorting Wire	13

CHAPTER 1

General Description

The Hy-Gain Discoverer 7-1 is a single-element dipole antenna for the Amateur 40 meter band. The Discoverer 7-1 incorporates the principles of linear-loading which results in lower loss and greater radiation efficiency than what is possible with loading coils. The Discoverer 7-1 is also capable of being tuned to any frequency between 7.0 and 10.5 MHz due to the linear-loading.

The Discoverer 7-1 features stainless steel hardware and clamps on all electrical and most mechanical connections.

WARNING

When installing your system, take extreme care to avoid any accidental contact with power lines or overhead obstructions. Failure to exercise this care could result in serious or fatal injury.

Specifications

Mechanical

Total Number of Elements	1
Maximum Element Length	45 ft. (13.7 m)
Boom Length	2.17 ft. (661 mm)
Boom Diameter	2 in. (51 mm)
Turning Radius	22.5 ft. (6.9 m)
Accepts Mast	1.25-2.5 in. (38-64 mm)
Maximum Wind Survival	100 mph (161 kmph)
Wind Surface Area	2.7 sq. ft. (0.25 sq. m)
Wind Load at 80 mph	69 lbs (31.3 kg)
Net Weight	23 lbs. (10.4 kg)
Hardware	stainless steel except for 7 large bolts in the boom-to-mast bracket
Suitable Rotators	AR40, CD 45II

Electrical

Gain	1.7 dBi (-0.5 dBd) average
Front-to-Back Ratio	0 dB
Front-to-Side Ratio	30 dB min
Number of Settings	continuous adjustment
Bandwidth:	
3:1 VSWR	350 kHz @ 7.2 MHz
2:1 VSWR	220 kHz @ 7.2 MHz
VSWR at Resonance	less than 1.3
Nominal Impedance	50 ohms

CHAPTER 4

Preparation for Assembly

FOR OUR OVERSEAS CUSTOMERS: The United States uses English units of measurements. Please refer to "Converting English Measurements to Metric" in Chapter 4 for any conversions.

Choose a large clear area to assemble your antenna. The area must be at least 3 feet by 45 feet (approximately 1 meter by 14 meters). If you assemble the antenna over a grassy area, precautions should be taken so that hardware is not accidentally lost during assembly. A concrete driveway is an excellent area for assembly.

TOOLS: The following tools are required for easy assembly of the Discoverer 7-1.

When unpacking your antenna, check inside of all tubing for parts (smaller tubing, etc.). To conserve space, these smaller articles are sometimes put inside larger pieces. Check all parts against the Parts List to make sure no parts are missing.

All tubing supplied with the Discoverer 7-1 telescopes together. Make all measurement to the given dimensions, plus or minus (\pm), no more than $1/8$ inch! The assembly of this antenna will be easier if you read this manual completely through at least twice before beginning assembly. Allow at least 2 hours for assembly. Double and triple check ALL dimensions after assembly.

Type of Tool Qty	
Tape Measure, 12 foot	1
Adjustable Wrench, 8 inch	2
Nut Driver, 7/16 inch	1
Nut Driver, /8 inch	1
Nut Driver, 5/16 inch	1
Standard Hand Pliers	1

CHAPTER 5

Assembly of the Boom-to-Mast Brackets and Boom

Select the 2" x 26" boom section (Item No. 5), the two cast aluminum brackets (Item No. 1), the casting-to-boom bracket (Item No. 2), the boom-to-bracket clamp (Item No. 3), and the appropriate hardware. Assemble as shown in Figure 1.

The use of two split lockwashers on the 5" bolts may be necessary to properly tighten the clamp on a 2" mast. Additional washers may be needed if masts slightly smaller than 2" are used.

When you are ready to install the antenna on your mast, the two cast aluminum brackets can be mounted first, using the 3 inch bolts (Item No. 24). Then the assembled antenna can be installed upon these brackets using the four (4) 5 inch bolts (Item No. 23).

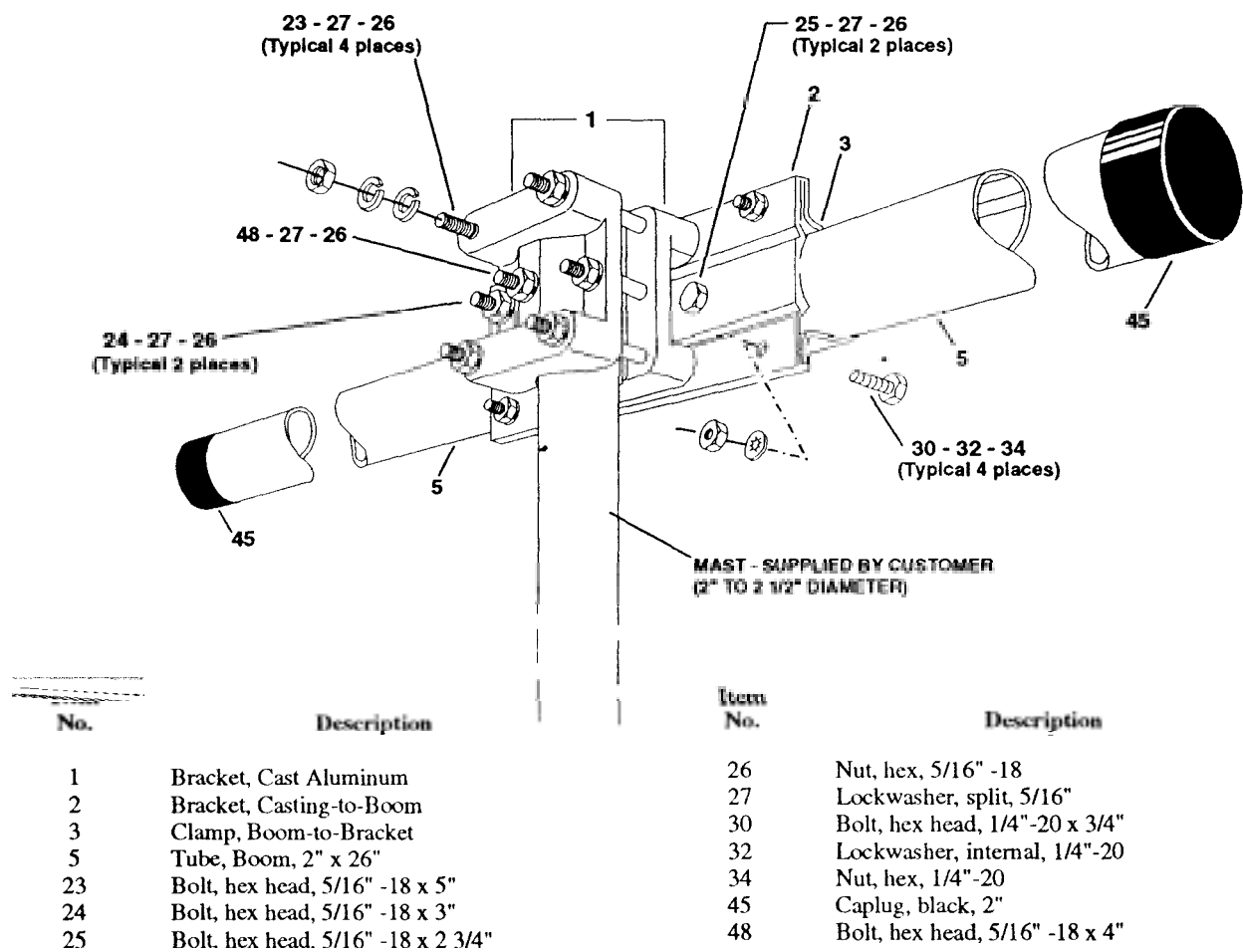

Figure 1 Boom-to-Mast
Bracket

Assembly of the Driven Element

Select a set of element-to-boom brackets (Item No. 4) and loosely assemble on the long end of the boom as shown in Figure 2. The brackets should just clear the 2" caplug when tightened down.

Select the DEI sections (Item No. 10) and a set of element insulators (Item No. 17). Slip the thick-walled ends of the DE I sections into the insulators then slip the insulated end into the brackets which are assembled on the boom.

Turn the boom so that the element will be at 90 degrees to the mast, and tighten all of the bolts to hold the element securely. Tighten the two anchor bolts (Item No. 28) last. Make sure that the three small holes in each DEI section are in the vertical plane. See Figure 2.

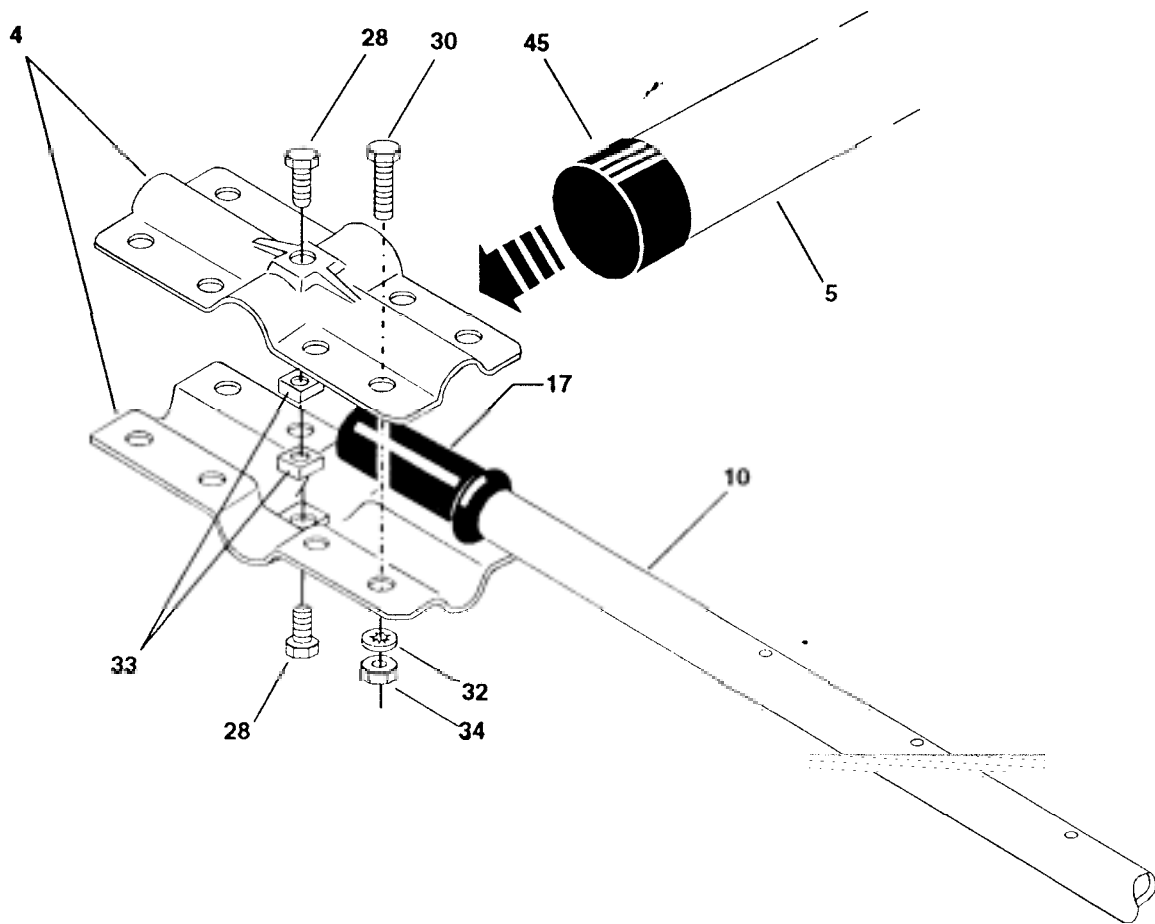

Item No.	Description	Item No.	Description
4	Bracket, Element-to-Boom, #14	30	Bolt, hex head, 1/4" -20 x 3/4"
5	Tube, Boom, 2" x 26"	32	Lockwasher, internal, 1/4"-20
10	Tube, Element, DEI, 1 1/4" x 83"	33	Nut, square, 1/4" -20
17	Insulator, Element, DEI	34	Nut, hex, 1/4" -20
28	Bolt, hex head, 1/4" -20 x 3/8"	45	Caplug, black, 2"

Figure 2 Assembly of the Element-to-Boom Brackets

Select the DE2 sections (1" x 51", Item No. 9) and slip the end with the 1/4 inch hole into the end of the DE1 sections. Align the holes and fasten securely with a 1/4"-20 x 1 1/2" bolt, lockwasher and nut (Item Nos. 29, 32 & 34). See Figure 3.

Select the 40-meter element insulators (Item No. 16) and slip each onto the ends of the DE2 sections which were previously installed. Line up the holes in each part and secure using #10-24 x 2" bolts, lockwashers and nuts (Item Nos. 35, 40 & 38).

Select the DE3 sections (7/8" x 55", Item No. 8) and slip the drilled ends into the open end of the 40-meter element insulators. Line up the holes and secure using #10-24 x 2" bolts, lockwashers and nuts (Item Nos. 35, 40 & 38).

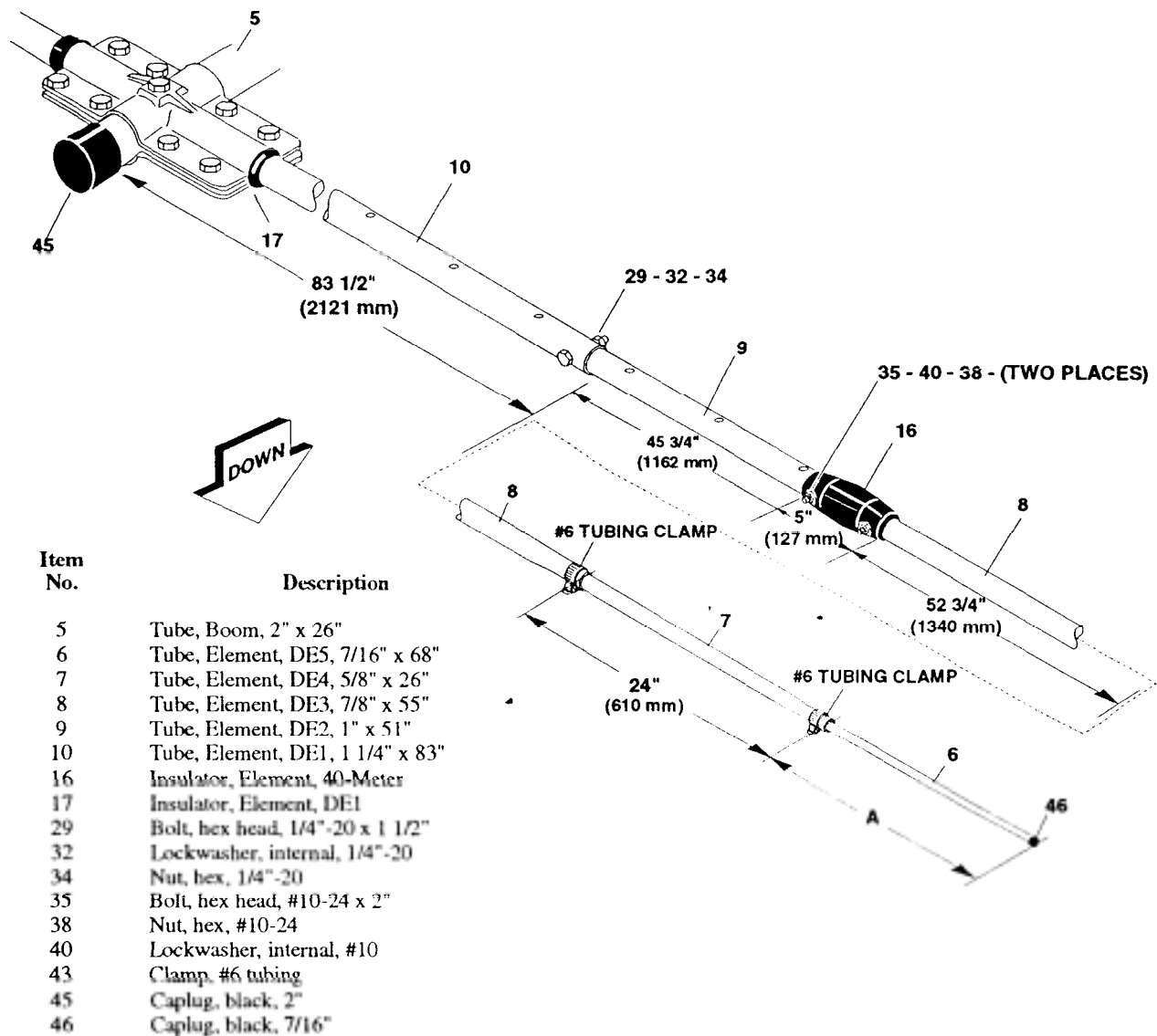

Figure 3 Assembly of the Driven Element

Assemble a 3/4" compression clamp (Item No. 44) and slip it over the end of the DE3 section. See Figure 4.

Select the DE4 section (5/8" x 26", Item No. 7) and slip the unswaged end into the DE3 section. Adjust the length to 24" as shown in Figure 3. Tighten the 3/4" compression clamp.

Assemble a 1/2" compression clamp (Item No. 43) and slip it over the end of the DE4 section. See Figures 3 and 4.

Select the DES section (7/16" x 68", Item No. 6) and slip it into the DE4 section. Adjust the length of this section to the dimensions shown in Figure 5 for 40-meter operation.

Place a 7/16" caplug (Item No. 47) on each end of the DE5 sections.

Installation of Tubing Clamps

When installing the clamps, place the clamp near the tube end with the top of the clamp over the slot in the tube as shown in the illustration.

After adjustment of the tubing lengths, tighten the clamp with a 5/16 inch nut driver or open end wrench until the tubing will not twist or telescope.

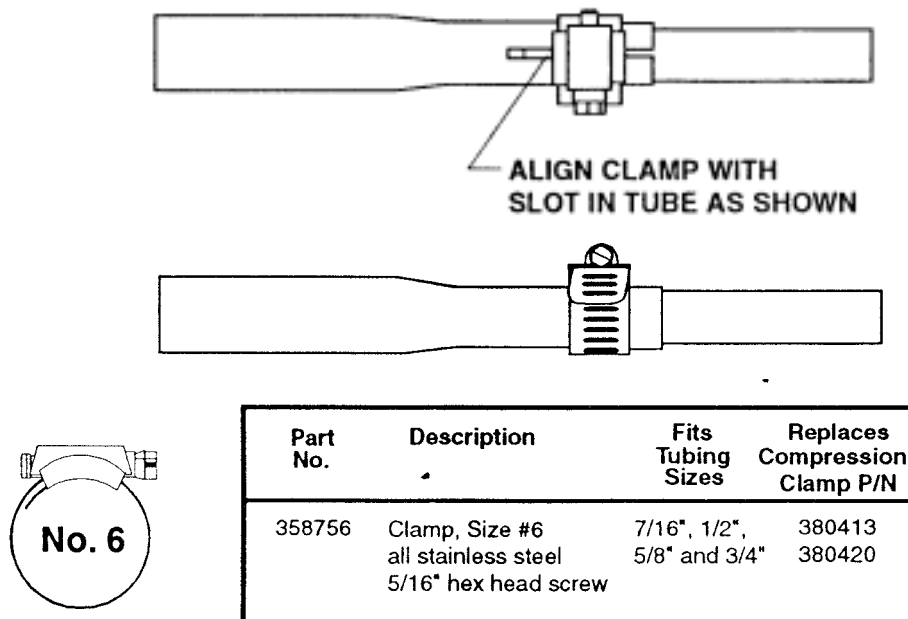

Figure 4 Tubing Clamps

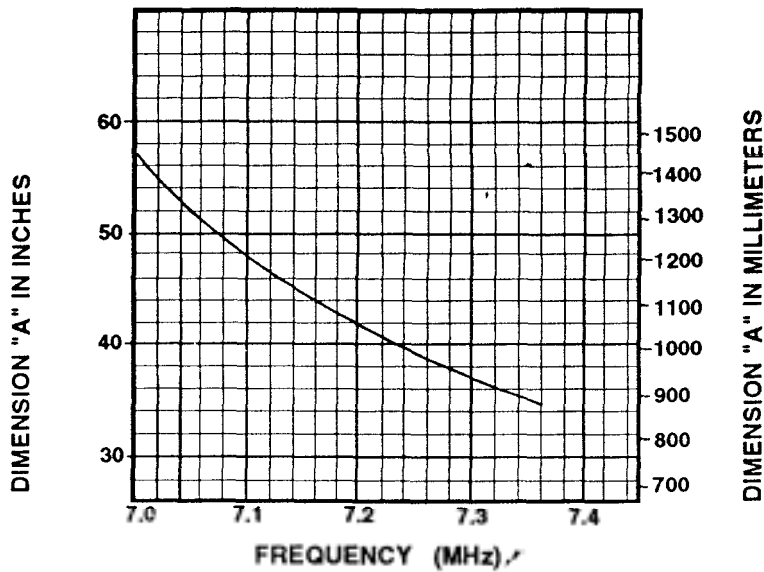

Chart 1 DE5 Section
Dimension Chart

Linear-Loading Wire Assembly

Select the 24 rod support insulators ("Tombstone"-shaped) (Item No. 47) and install them on the DE1 and DE2 sections as shown in Figure 6, using the #6-32 x 2" bolts, lockwashers and nuts (Item Nos. 20, 22 & 21).

Select the four (4) 7/8" aluminum tubing clamps (Item No. 42) and install these on the DE2 and DE3 sections on either side of the 40-meter insulator as shown in Figure 7, using the 1/4" - 20 x 1 1/4" (Item No. 3) and 1/4"-20 x 1 1/2" bolts, nuts (Item Nos. 29, 32 & 34).

Identify the LLW sections from the drawing in Figure 8 and assemble as shown in Figure 6, using the #10-24 x 1/2" bolts, lockwashers and nuts (Item Nos. 36, 40 & 38).

Start assembling the LLW sections to the element beginning at the 40 meter insulator. Position the tubing clamps (Item 42) as close as possible to the 40 meter insulator as shown below. Other clamp and wire positions will depend upon the final assembly of the linear loading wires.

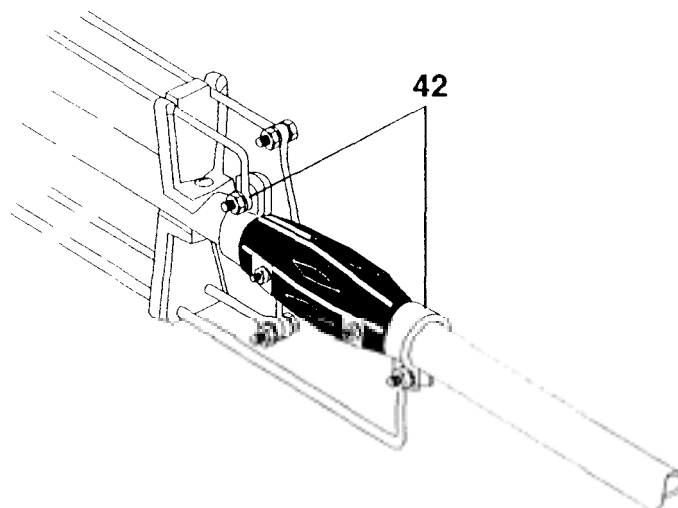
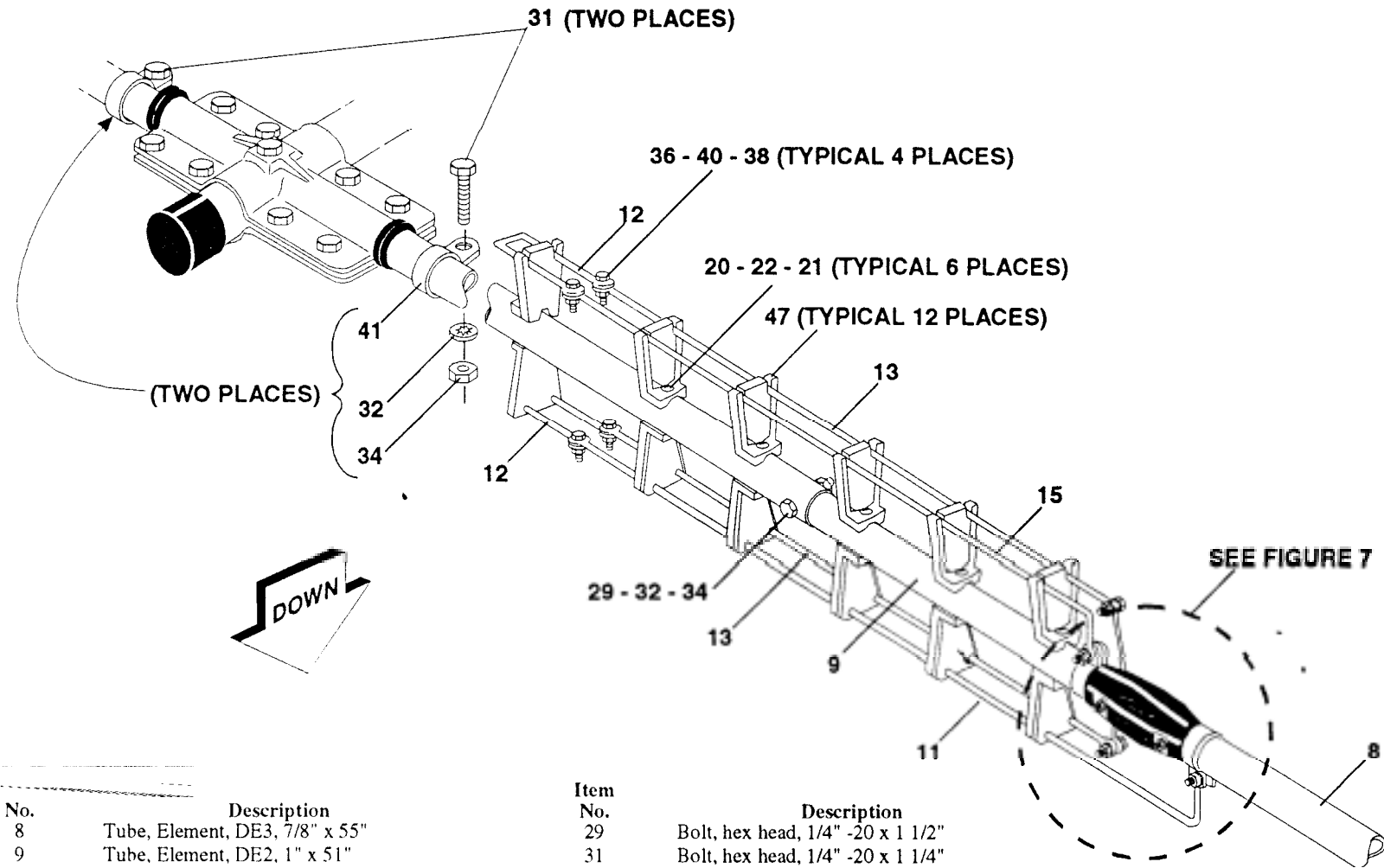

Figure 5 Position of Tubing
Clamps



No.	Description	Item No.	Description
8	Tube, Element, DE3, 7/8" x 55"	29	Bolt, hex head, 1/4" -20 x 1 1/2"
9	Tube, Element, DE2, 1" x 51"	31	Bolt, hex head, 1/4" -20 x 1 1/4"
11	Hairpin, LLW1, 69"	32	Lockwasher, internal, 1/4" -20
12	Hairpin, LLW2, 28"	34	Nut, hex, 1/4"-20
13	Hairpin, LLW3, 63 1/2"	36	Bolt, hex head, #10-24 x 1/2"
15	Hairpin, LLW5, 63 1/2"	38	Nut, hex, #10-24
20	Bolt, round head, #6-32 x 2"	40	Lockwasher, internal, #10
21	Nut, hex, #6-32	41	clamp, Tubing, 1 1/4"
22	Lockwasher, internal, #6	47	Insulator, Rod Support

Figure 6 Installing "Hairpins" on Driven Element

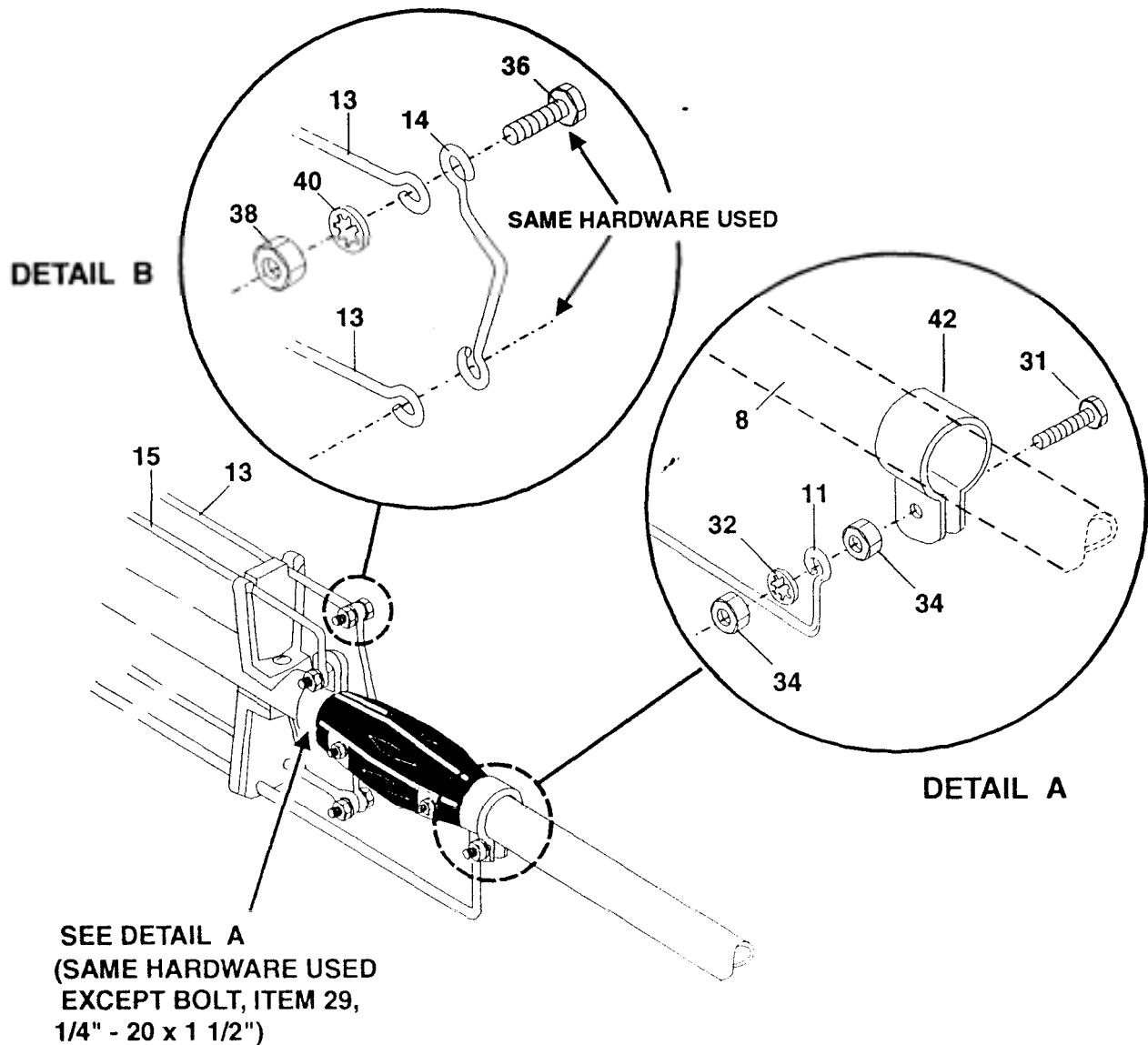
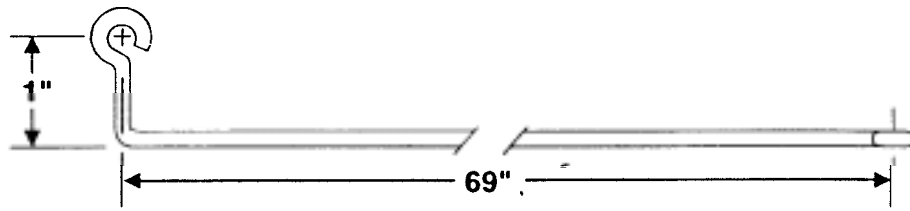

Figure 7 "Hairpin" Attachment Near 40-Meter Insulator

Final Assembly

Select the 1 1/4" tubing clamps (Item No. 41) and appropriate hardware and assemble as shown in Figure 6. Strip your coax cable, install solder lugs (not supplied) and connect to the dipole. Tape the cable to the boom for strain relief.

An RF choke made from 12 turns of RG-123/u coax in a 14" diameter circle is recommended with the split coax feed. An alternative method is to use a Hy-Gain BN-86 50 ohm balun for easy connection to your coax cable. "Pigtails" leads of #10 gauge stranded wire 7 inches long should be used from the balun to the tubing clamps.



Item No. 11 - PN 171283 - "Hairpin", LLW1

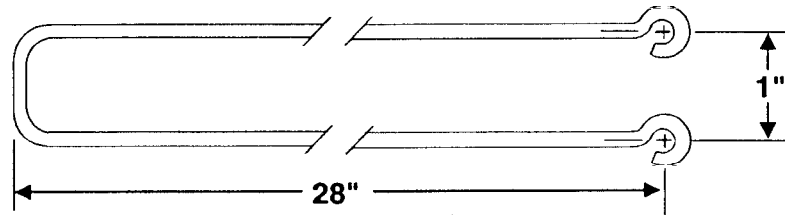

Item No. 12 - PN 171284 - "Hairpin", LLW2

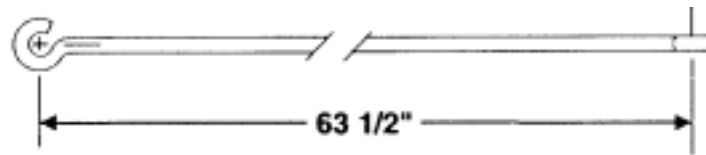

Item No. 13 - PN 171285 - "Hairpin", LLW3

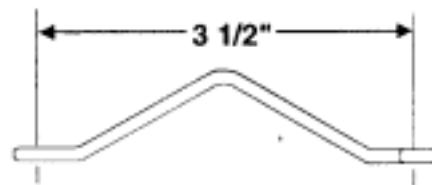

Item No. 14 - PN 171434 - "Hairpin", LLW4

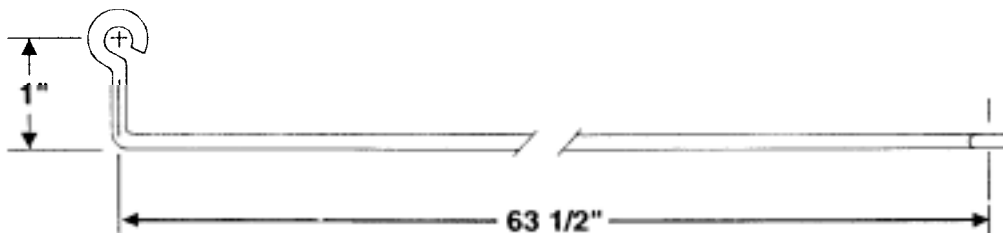

Item No. 15 - PN 171435 - "Hairpin", LLW5

Figure 8 Identification of Linear-Loading Wires (LLW)

CHAPTER 4

Adjustment for Operation Between 7.3 and 10.5 MHz

The Discoverer 7-1 can be adjusted to cover any frequency between 7.3 and 10.5 MHz instead of the normal 40-meter band. The VSWR at resonance will be less than 1.5:1 and 2:1 VSWR bandwidth will vary from 200 kHz at 7.3 MHz up to 750 kHz at 10.5 MHz.

On the 30 meter Amateur band at 10.1 MHz, typical 2:1 VSWR band width is 650 kHz.

To adjust the Discoverer 7-1 to a setting above 7.3 MHz, the linear-loading wires should be shorted out at the appropriate locations. The top and bottom linear-loading wires should both be shorted out at the same distance from the 40 meter insulator. See Figure 9. The "short" can be fabricated from a piece of short hook up wire twisted around the linear-loading wires at the specific location, and clamped in place using small guy wire clamps (not supplied). The DE5 section should be set at 40 inches for all frequencies within this range.

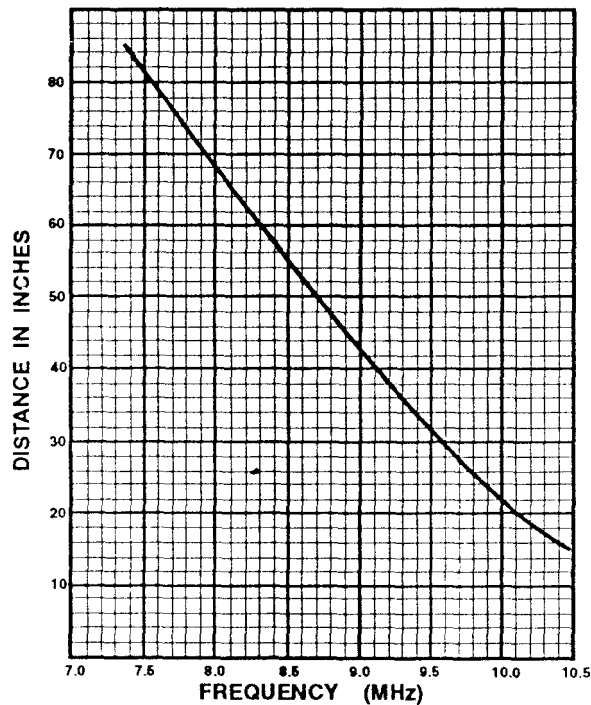

Figure 9 Adjustment of LLW
Shorting Wire

Installation

Select the two (2) cast aluminum brackets (Item No. 1) and two (2) 5/16"-18 x 3 1/4" bolts, lockwashers and nuts (Item Nos. 24, 27 & 26). Install these brackets on your mast where you want your antenna to be. Lift the Discoverer 7-1 up to the mounting location and attach to the cast brackets using the four (4) 5/16"-18 x 5" bolts, lockwashers and nuts (Item Nos. 23, 27 & 26). Tighten securely. Happy DX'ing.

Service Information

If you are unable to resolve technical problems, you should contact the Hy-Gain Customer Service Department in Lincoln, NE.

You should retain your sales receipt or other proof of purchase for antennas that are still under warranty. (See separate sheet for Telex Warranty.)

All requests, inquiries or warranty claims, or for ordering replacement parts contact:

PARTS LIST

Item No	Part No.	Description Qty
1	102734	Bracket, cast Aluminum..... 2
2	172735	Bracket, Casting-to-Boom 1
3	172732	Clamp, Boom-to-Bracket 1
4	165920	Bracket, Element-to-Boom, #14 2
5	171282	Tube, Boom 2" x 26..... 1
6	174868	Tube, Element, DE5, 7/16" x 68..... 2
7	190006	Tube, Element, DE4, 5/8" x 26..... 2
8	191007	Tube, Element, DE3, 7/8" x 55..... 2
9	878241	Tube, Element, DE2, 1" x 51" 2
10	878242	Tube, Element, DE1, 1 1/4" x 83" 2
11	171283	Hairpin", LLWI, 69" .. / 2
12	171284	"Hairpin", LLW2, 28..... 4
13	171285	"Hairpin", LLW3, 63 1/2" 4
14	171434	"Hairpin", LLW4, 3 1/2" 2
15	171435	"Hairpin", LLW5, 63 1/2" 2
16	460316	Insulator, Element, 40 Meter..... 2
17	465833	Insulator, Element, DE1 2
18		(Not Used)
19		(Not Used)
	878243	Parts Pack, 371S, Stainless Steel Hardware 1
20	500143	Bolt, round head, #6-32 x 2..... 12
21	555888	Nut, hex, #6-32 12
22	565889	Lockwasher, internal, #6..... 12
23	500349	Bolt, hex head, 5/16"-18 x 5..... 4
24	500392	Bolt, hex head, tap, 5/16" x 18 x 3..... 2
25	506968	Bolt, hex head, 5/16"- 18 x 2 3/4" . . . ' 2
26	555747	Nut, hex, 5/16" -18..... 9
27	564792	Lockwasher, split, 5/16..... 9
28	500156	Bolt, hex head, 1/4"- 20 x 3/8..... 4
29	504098	Bolt, hex head, 1/4"- 20 x 1 1/2..... 4
30	505266	Bolt, hex head, 1/4"- 20 x 3/4..... 12
31	506518	Bolt, hex head, 1/4"- 20 x 1 1/4..... 6
32	562961	Lockwasher, internal, 1/4"-20..... 30
33	551367	Nut, square, 1/4"- 20..... 2
34	554099	Nut, hex, 1/4"-20..... 28
35	500157	Bolt, hex head, #10-24 x 2..... 4
36	500158	Bolt, hex head, #10-24 x 1/2..... 14
37		(Not Used)
38	554071	Nut, hex, # 10-24 20
39		(Not Used)
40	565697	Lockwasher, internal, #10..... 16

Parts List

41	878244	Parts Pack, 371 S, Clamps and Misc.....	1
	168695	Clamp, Tubing, 1 1/4.....	2
42	169339	Clamp, Tubing, 7/8.....	4
43	358756	Clamp, Tubing #6.....	4
44		(Not Used)	
45	455625	Caplug, black, 2.....	2
46	455644	Caplug, black, 7/16.....	2
47	463642	Insulator, Rod Support	24
48	5142400	bolt, hex head, 5/16"-18 x 4.....	1

Converting English Measurements to

Use this scale to identify lengths of bolts, diameters
cm of tubes, etc.. The English inch(") and foot (') can
be converted to centimeters in this way.

$$1 \text{ inwh (1 ") = 2.54}$$

$$1 \text{ foot (1') = 30.48}$$

$$\text{Example: } 42" \times 2.54 = 106.7 \text{ cm}$$

