

DIS-72 Discoverer
7-2 40-Meter 2-Element
HF Beam

Instruction Manual

Hy-gain

308 Industrial Park Road
Starkville, MS 39759

Please record the following information for your records: Date
of Purchase:
Purchased From Price Paid
Please retain your copy of the Bill-of-Sale for Warranty
claims.

TABLE OF

CHAPTER 1- GENERAL DESCRIPTION.....		
1-1	General	Description
.....		1-1
CHAPTER 2 - PRE-ASSEMBLY INFORMATION.....	2-1 Preparation for Assembly	
		CHAPTER 3 - ASSEMBLY
.....		3-1 Assembly of the
Boom-to-Mast Brackets and Boom.....	3-1 Element-to-	
Boom Brackets.....	3-2	
	Assembly of the Driven	
Element.....	3-2 Tubing	
Clamps.....	3-4	
	Assembly of the Reflector Element	
.....	3-5 Driven Element and Reflector	
Linear-Loading Wire Assembly.....	3-8 Beta Match Assembly	
.....	3-11 Lightning	
CHAPTER 4 - INSTALLATION		
.....	4-1	
Installation.....		
.....4-1 Installation on a Crank-Up		
Tower	4-1 Attaching the	
CHAPTER 5 - SERVICE/PARTS LIST.....	5-1 Service Information	
.....	5-1 Parts	
List		5

LIST OF

Figure

Pag

e			
1	Assembly of Boom Tubes to Casting-to-Boom Bracket and Boom-to-Bracket Clamp.....	3-1	2
	Boom Brackets		3-2
	Assembly of the Driven Element	3-3	
4	Tubing Clamps		3-4
5	VSWR Charts.....		3-4
6	Front-to-Back Charts		3-5

CHAPTER I - GENERAL INFORMATION

General Description

The Hy-Gain Discoverer 7-2 is an optimum spaced, two element beam for the 40 Meter Amateur band. The Discoverer 7-2 incorporates the principles of linear-loading which results in lower loss and greater radiation efficiency than is possible with loading coils.

The Discoverer 7-2 features stainless steel hardware and clamps on all electrical and most mechanical connections.

WARNING

When installing your system, take extreme care to avoid any accidental contact with power lines or overhead obstructions. Failure to exercise this care could result in serious or fatal injury.

SPECIFICATIONS

Mechanical

Total Number of Elements.....	2
Maximum Element Length	44.8 ft. (13.7 m)
Boom Length.....	22.6 ft. (6.9 m)
Boom Diameter.....	2 in. (51 mm)
Turning Radius	25.0 ft (7.6 m)
Accepts Mast	1.625 - 2.5 in. (41-64 mm)
Maximum Wind Survival	80 mph (128.7 kmph)
Wind Surface Area.....	6.0 sq. ft. (0.56 sq. m)
Effective Moment*.....	1412 ft.-lb. (192 kg-m)
Wind Load at 80 mph	154
Hardware.....	stainless steel hardware and clam

Electrical

Suitable Rotors.....	Hv-Gain Ham
Maximum Gain.....	f)J dBi (4.3 dBd)
Front-to-BackRatio(maximum).....	15 dB
Number of Settings.....	3
Band Width	
10 dB Front-to-Back.....	70 - 90 KHz 3:1
VSWR.....	275 KHz @ 60 ft.
2:1 VSWR.....	187 KHz @ 60 ft.
VSWR at Resonance	less than 1.2
Nominal Impedance.....	50 ohms
Lightning Protection.....	DC ground -3 dB
Beam Width	77 degrees @ maximum Front-to-

*Effective Moment is defined as the product of the weight of the antenna and the turning radius. This figure should be used when selecting an appropriate rotator.

CHAPTER 2 -PRE-ASSEMBLY

Preparation for Assembly

FOR OUR OVERSEAS CUSTOMERS:

The United States uses American units of measurement. If you use the Metric System, see "Converting American Measurements to Metric"

Choose a large clear area to assemble your antenna. The area must be at least 23' x 45' (7m x 14m). If you assemble this antenna over a grassy area, precaution should be taken so that hardware is not accidentally lost during assembly. A concrete driveway is an excellent area for assembly.

TOOLS: The following tools are required for 'easy assembly of the Discoverer 7-2.

TYPE OF TOOL

Tape Measure, 12 foot

Adjustable Wrench, 8 inch

Nut Driver, 7/16 inch

Nut Driver, 3/8

Nut Driver, 5/16 in

Standard Hand

NOTE: When unpacking your antenna, check inside of all tubing for parts (smaller tubing etc.). To conserve space these smaller articles are sometimes put inside larger pieces. Check all parts against the Parts List to make sure no parts are missing.

All tubing supplied with the Discoverer 7-2 telescopes together. Make all measurement to the given dimensions, plus or minus (+/-), no more than 1/8 inch! The assembly of this antenna will be easier if you read this manual completely through at least twice before beginning assembly. Allow at least 6 hours for assembly. Double and triple check ALL dimensions after assembly.

Corrosion Precautions

The Discoverer 7-2 antenna is designed to be relatively maintenance free for most environments. All hardware is made of passivated stainless steel, typically grade 304. The internal tooth-type lockwashers used in this antenna are grade 410 stainless steel, and are slightly magnetic. The element tubing clamps are grade 304 stainless steel. Most other metallic parts are aluminum. All insulators exposed to sunlight are made from U.V resistant black polyethylene or black Cylolac®.

We have supplied a 3 oz. tube of Penetrox®A-3 from Bumdy Corporation for use as an anti-oxidant within element tubing assemblies. This prevents aluminum oxide from forming on the aluminum surfaces, especially in coastal environments.

Cut the cap off the tube of Penetrox®A-3. Have some rags available to clean off excess from tubing and hands. Be careful not to get this on your clothing.

Before assembling the tubing sections, abrade the mating surfaces with a wire brush or sandpaper. Apply the anti-oxidant to both surfaces, then assemble joint. Wipe off any excess material.

A light amount of clear lacquer or an acrylic spray may be used to coat the exterior surface of the element assemblies if this antenna is to be installed near a sea coast. Tighten all joints securely before coating !

[Penetrox®](#) is a registered trademark of Bumdy Corporation
[Cylolac®](#) is a registered trademark of Borg-Warner

CHAPTER 3 -

Assembly of the Boom-To-Mast Brackets and Boom

Refer to Figure 1 and begin as

Select the boom-to-bracket clamp and casting-to-boom bracket (Item Nos. 2 and 3) and loosely assemble them on the boom sections (Item No. 51) with the two 5/16"-18 x 2 3/4" bolts, split lockwashers and nuts (Item Nos. 25, 27 and 26 and the four (4) 1/4" - 20 x 3/4" bolts, internal lockwashers and nuts (Item Nos 30, 32 and 34).

Attach the remaining boom sections (Item No. 50) and secure with the two (2) 1/4" - 20 x 2 1/2" bolts, internal lockwashers and nuts (Item Nos. 53, 32 & 34). Tighten all hardware securely.

AO - 372S - C - 001

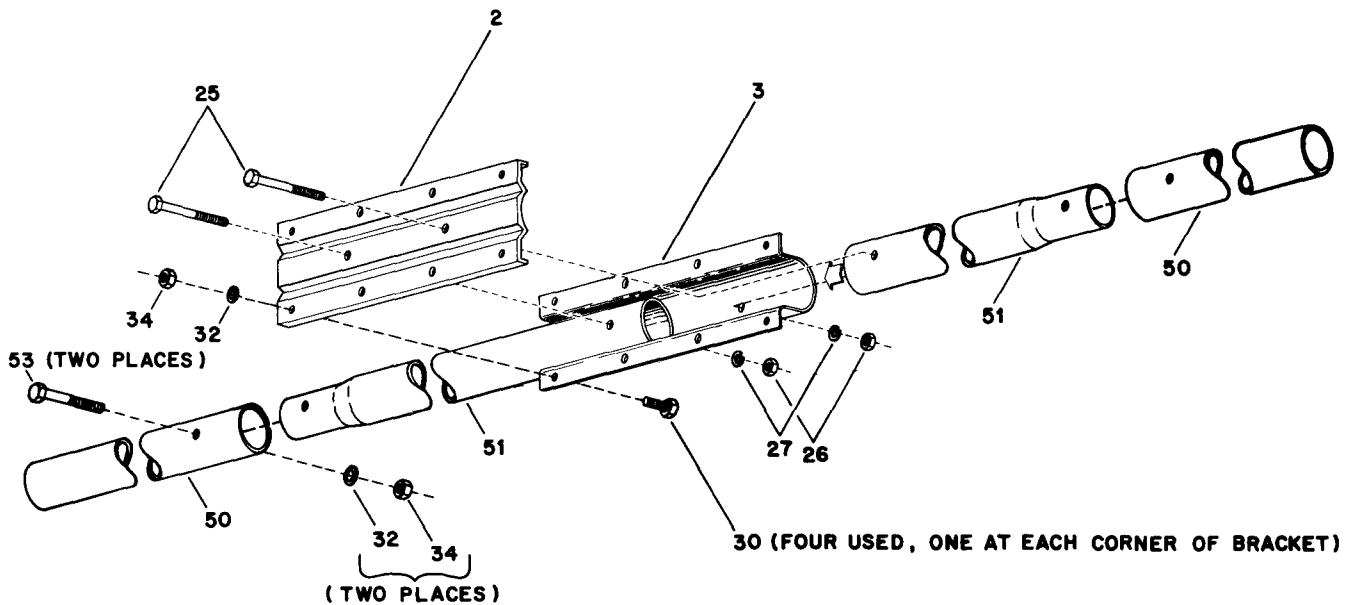

Item No.	Description	Item No.	Description
2	Bracket, Casting-to-Boom	32	Lockwasher, internal, 1/4" - 20
3	Clamp, Boom-to-Bracket	34	Nut, hex, 1/4" - 20
25.	Bolt, hex head, 5/16"-18 x 2 3/4"	50	Tube, Boom, 2" x 83" 83"
26	Nut, hex, 5/16" -18	51	Tube, Boom, 2" x 54 3/4",
27	Lockwasher, split, 5/16"	53	Bolt, hex head, 1/4" - 20 x 2 1/2"
30	Bolt, hex head, 1/4" - 20 x 3/4"		

Figure 1 Assembly of Boom Tubes to Casting-to-Boom Bracket and Boom-to-Bracket Clamp

Element-To-Boom

To save time, loosely assemble both of the element-to-boom brackets and their appropriate hardware before beginning further installation of the antenna. See Figure 2. The different sized brackets can be identified by a number stamped into the surface of each bracket half. **DO NOT** tighten the bolts until instructed to do so.

Slide each assembled bracket over each boom end. Position the center of each bracket 3 inches from the boom ends. **DO NOT** tighten at this time.

NOTE: ASSEMBLY HARDWARE FOR THE DRIVEN ELEMENT BRACKET IS THE SAME AS USED ON THE REFLECTOR BRACKET.

Assembly of the Driven Element

Select the parts, as listed in Figure 3, and assemble them as shown. Before tightening the hardware, make sure that:

DE1 (Item No. 10) is inserted completely into the driven element insulator.

DE1 (Item No. 10) is positioned with the small holes up and down.

DE1 (Item No. 10) is positioned at 90 degrees from the boom-to-mast bracket, so that the element will be horizontal when installed on the mast.

AO-372S-B-007

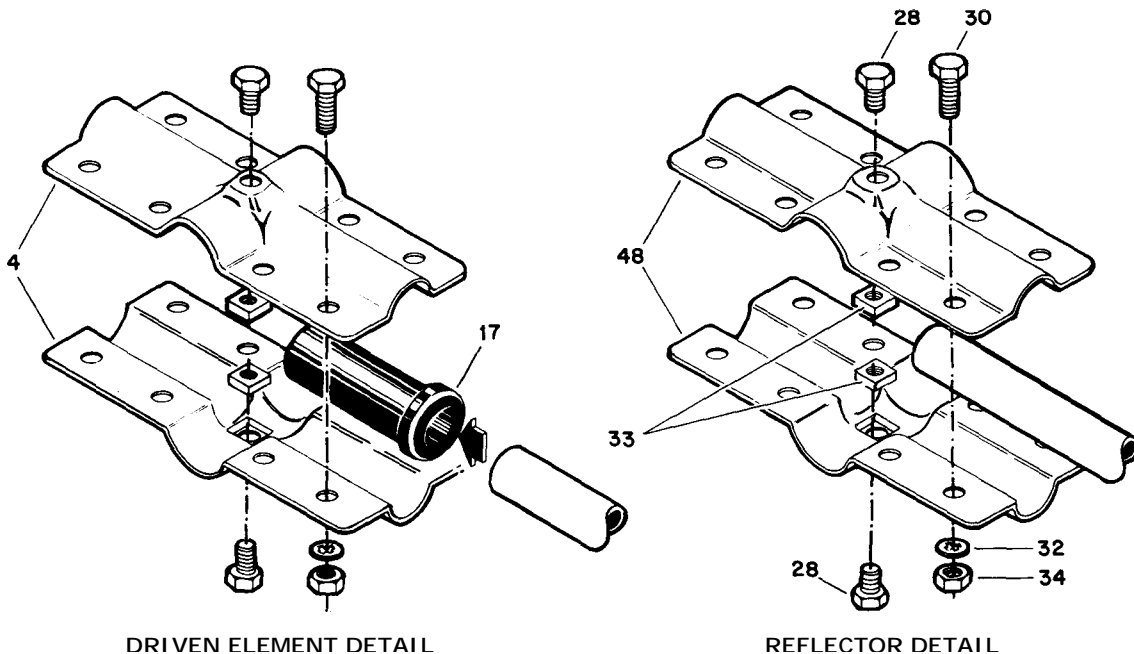

DRIVEN ELEMENT DETAIL

REFLECTOR DETAIL

Item No.	Description
4 17	Bracket, Element-to-Boom, #14 "
28	Insulator, Element, DE1
30	Bolt, hex head, 1/4"--20 x 3/8"
32	Bolt, hex head, 1/4"--20 x 3/4"
33	Lockwasher, internal,
34	1/4"-20 Nut, square, 1/4"--20
48	Nut, hex, 1/4"--20

Figure 2 Element-to-Boom Brackets

Tighten the anchor bolts on the element-to-boom bracket (Item No. 28) last. This will ensure that the element will not slip on the boom.

A0- 372S -B-

Setting	"A" Dimension		One Half DE Length*	
	(Inches)	(mm)	(Inches)	(m)
Cw	47	1194	258	6.553
MID	44	1118	255	6.478
PHONE	41	1041	252	6.401

*Measured from boom edge to element tip.

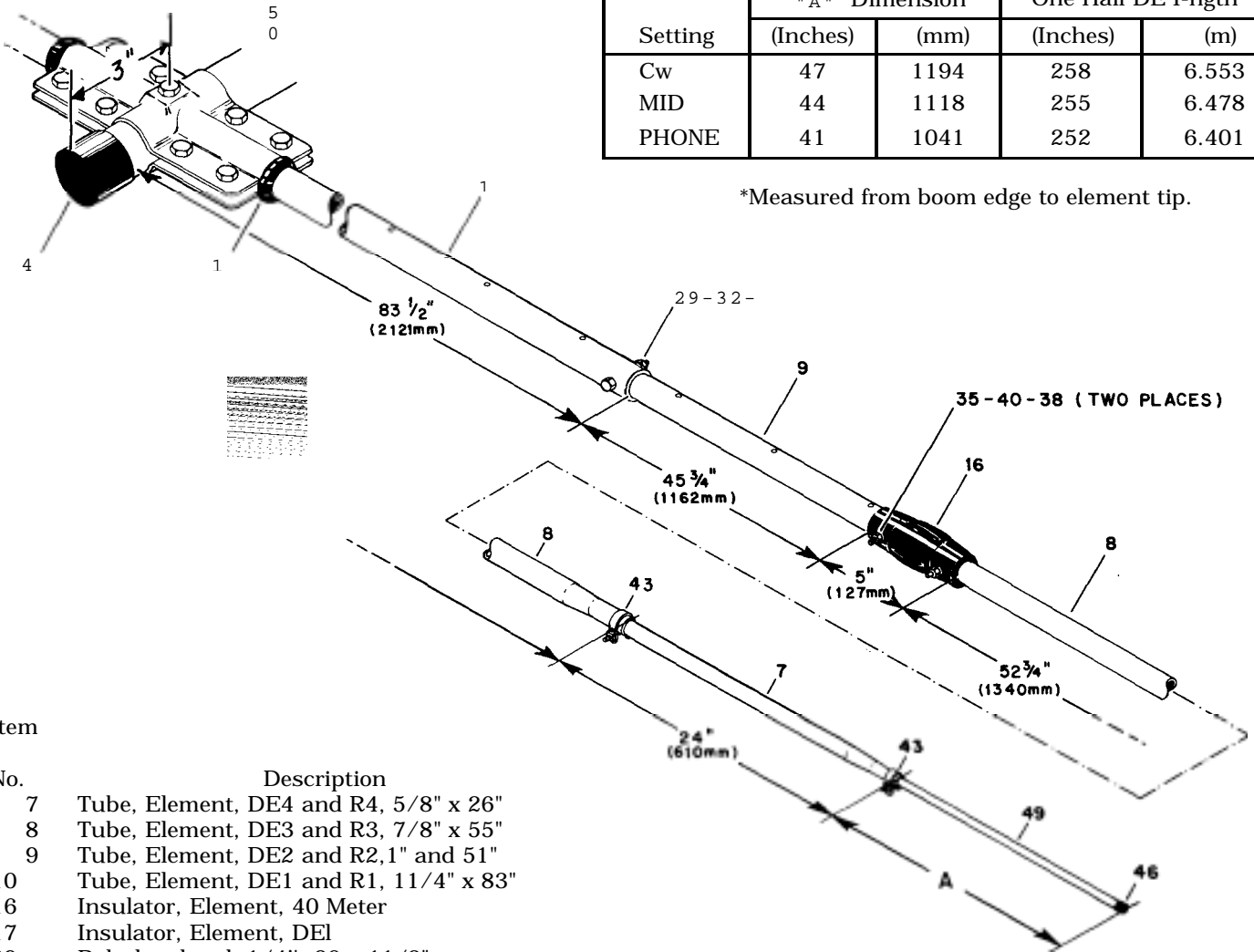

Item No.	Description
7	Tube, Element, DE4 and R4, 5/8" x 26"
8	Tube, Element, DE3 and R3, 7/8" x 55"
9	Tube, Element, DE2 and R2, 1" and 51"
10	Tube, Element, DE1 and R1, 1 1/4" x 83"
16	Insulator, Element, 40 Meter
17	Insulator, Element, DE1
29	Bolt, hex head, 1/4" - 20 x 1 1/2"
32	Lockwasher, internal, 1/4" - 20
34	Nut, hex, 1/4" - 20
35	Bolt, hex head, #10 - 24 x 2"
38	Nut, hex, #10 - 24
40	Lockwasher, internal, #10
43	Tubing Clamp
45	Caplug, black, 2"
46	Caplug, black, 7/16"
49	Tube, Element, DE5, 7/16" x 58"
50	Tube, Boom, 2" x 83"

Figure 3 Assembly of the Driven Element

Installation of Tubing

Select the #6 tubing clamp as shown in the chart. When installing the clamp, place the clamp near the tube end with the top of the clamp over the slot in the tube as shown in Figure 4.

After adjustment of the tubing lengths, tighten the clamp with a 5/16 inch nut driver, socket, or open end wrench until the tubing will not twist or telescope.

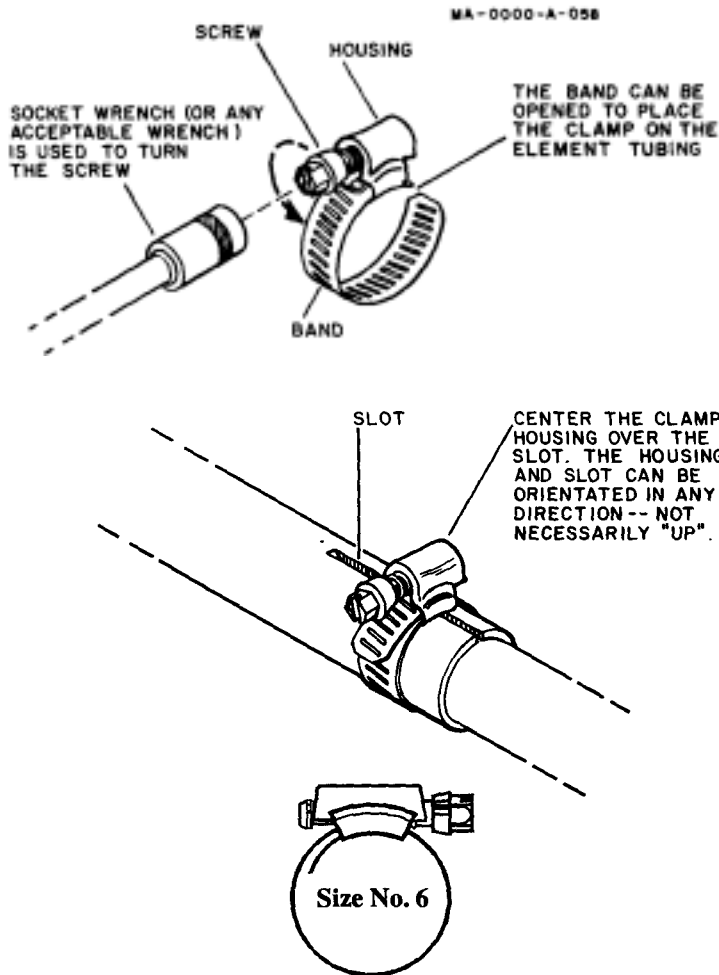

Part No.	Description	Fits Tubing Sizes
358756	Clamp, Size #6 all stainless steel 5/16" hex head screw	1/2 and 3/4"

Figure 4
Tubing Clamps

Refer to Figure 4 for tubing clamp assembly information. Tighten these clamps securely after setting Item Nos. 7 and 49 to their proper length.

The Discoverer 7-2 is supplied with dimensions for three (3) settings within the 40 Meter Amateur band. The three (3) settings are entitled CW, MID, and PHONE. The CW setting is optimized for operation from 7.00-7.15 MHz. The MID setting is optimized for operation from 7.05-7.25 MHz and the PHONE setting is optimized for operation from 7.15-7.30 MHz.

The VSWR, Front-to-Back Ratio, and Gain curves are shown in Figures 5, 6, and 7. From this information, choose one of the three settings to use.

Set the length of the DE5 section A to one of the lengths shown in Table 1.

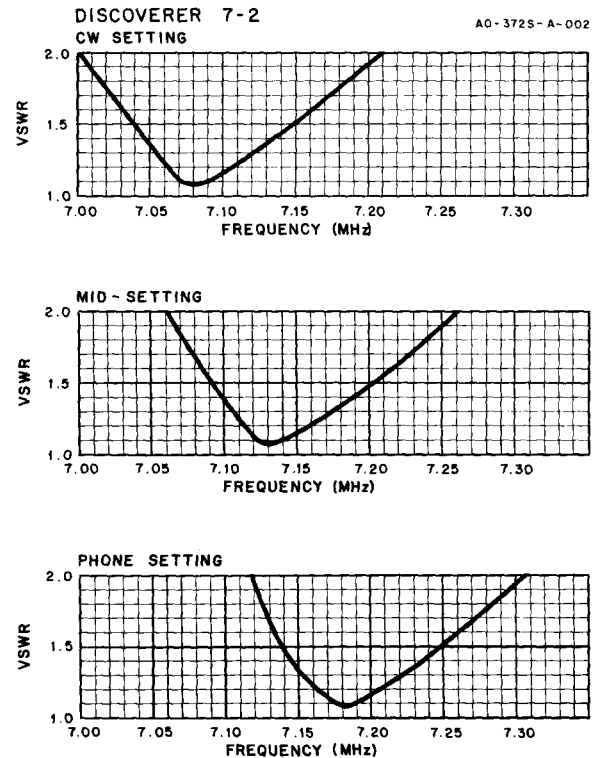

Figure 5
VSWR Charts

Assembly of the Reflector Element

Select the parts listed in Figure 8 and assemble them as shown. Before tightening the hardware, make sure that:

R1 (Item No. 10) is inserted completely into the element-to-boom brackets.

R1 (Item No. 10) is positioned with the small holes up and down.

R1 (Item No. 10) is positioned so that the element will be horizontal when installed on the mast.

Tighten the anchor bolts (Item No. 28) last. This will ensure that the element will not slip on the boom.

Refer to Figure 4 for tubing clamp assembly information. Tighten these clamps securely after setting Item Nos 6 & 7 to their proper length.

Set the length of the RS section ("B") to one of the lengths in Table 2. The reflector and driven element must both be adjusted to the same setting for proper operation.

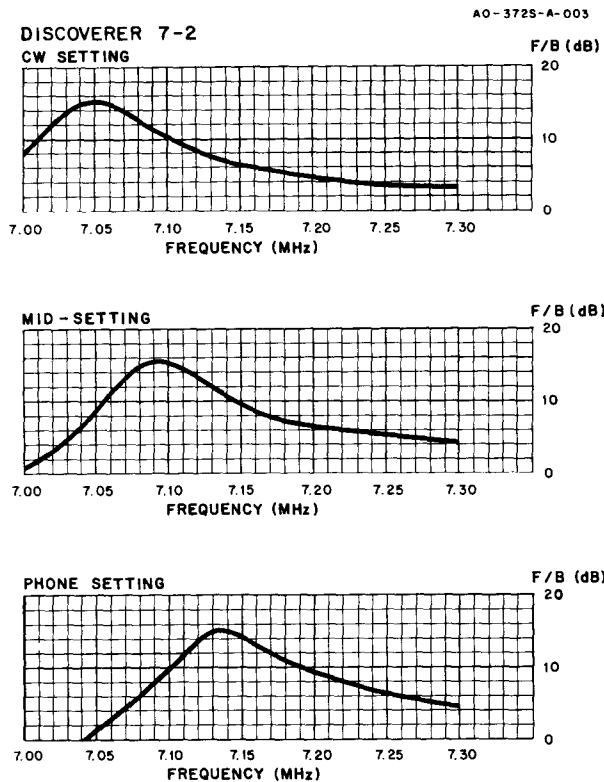

Figure 6
Front-to-Back Ratio Charts

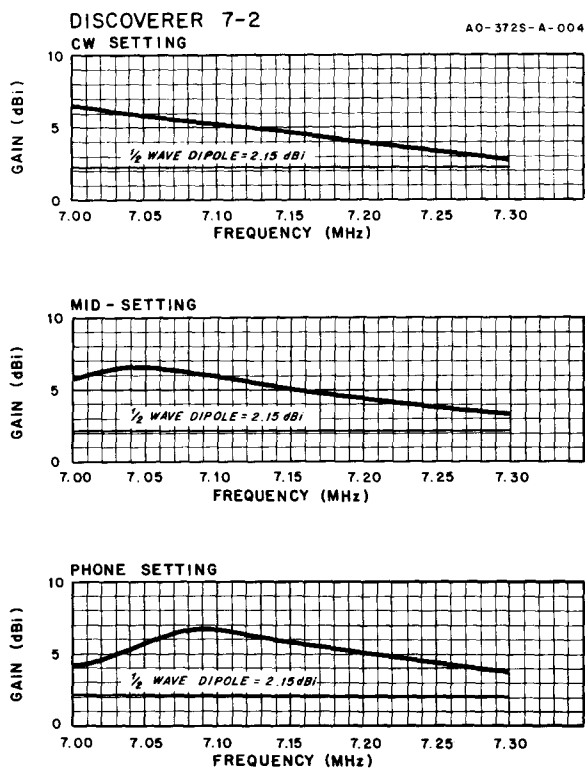

Figure 7
Gain Chart

Setting	"B" Dimension		1/2 Reflector Length*	
	(Inches)	(mm)	(Inches)	(m)
CW	57	1448	267.5	6.795
MID	54	1372	264.5	6.719
PHONE	51	1295	261.5	6.642

*Measured from boom edge to element

Table 2

AO-3725-B-009

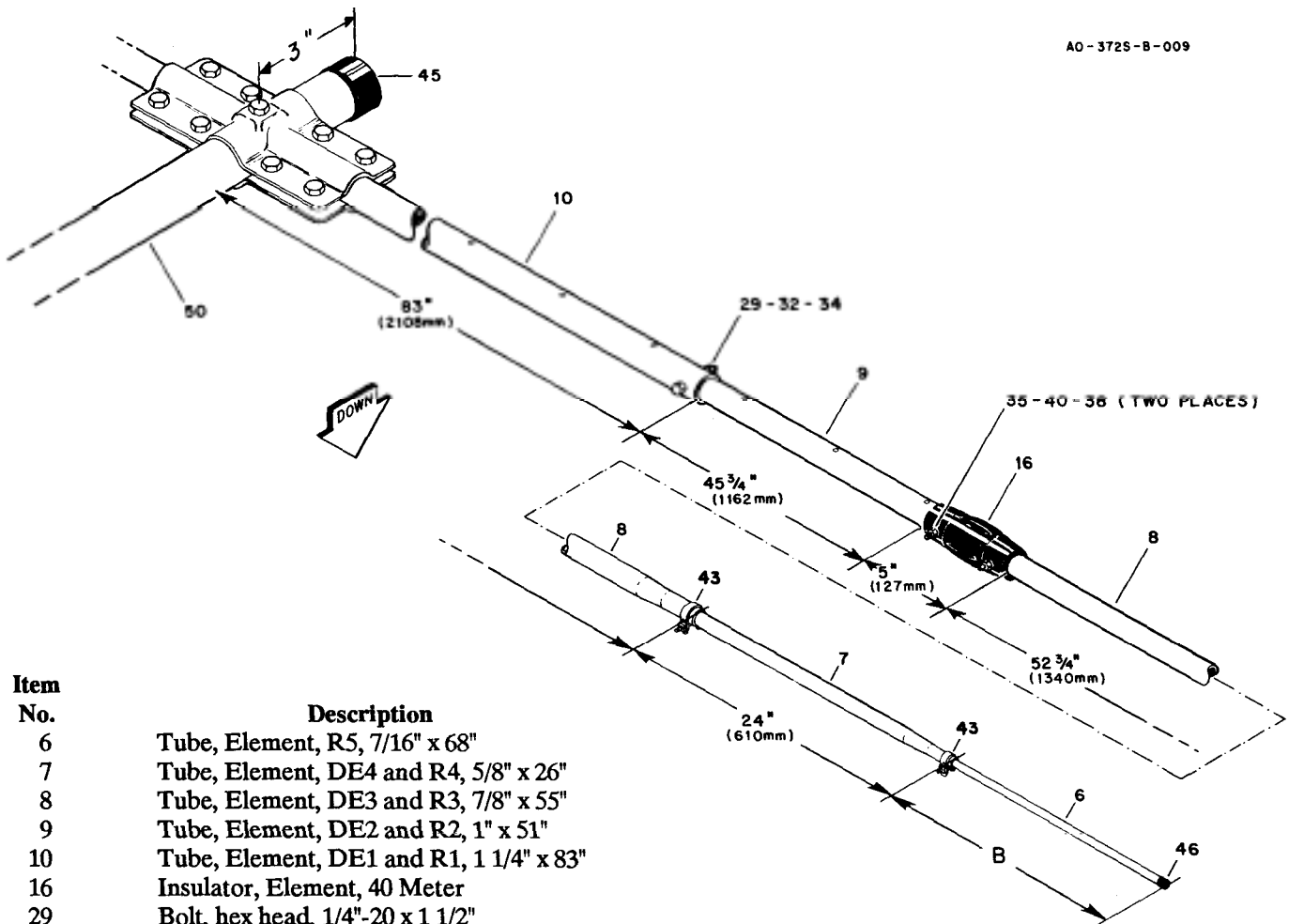

Item No.	Description
6	Tube, Element, R5, 7/16" x 68"
7	Tube, Element, DE4 and R4, 5/8" x 26"
8	Tube, Element, DE3 and R3, 7/8" x 55"
9	Tube, Element, DE2 and R2, 1" x 51"
10	Tube, Element, DE1 and R1, 1 1/4" x 83"
16	Insulator, Element, 40 Meter
29	Bolt, hex head, 1/4"-20 x 1 1/2"
32	Lockwasher, internal, 1/4"-20
34	Nut, hex, 1/4"-20
35	Bolt, hex head, #10-24 x 2"
38	Nut, hex, #10-24
40	Lockwasher, internal, #10
43	Tubing Clamp
45	Caplug, black, 2"
46	Caplug, black, 7/16"
50	Tube, Boom, 2" x 83"

Figure 8
Assembly of Reflector Element

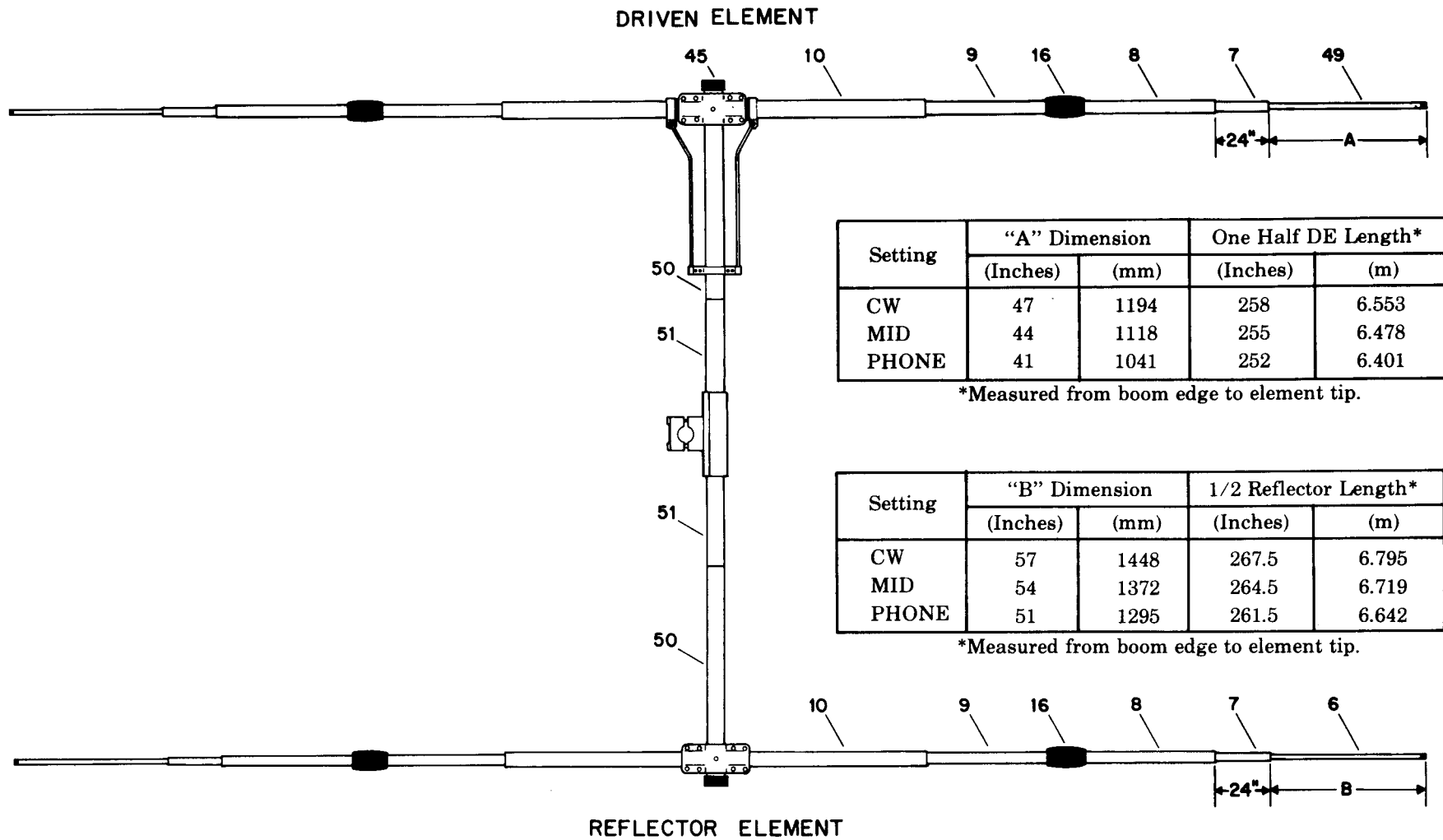

3-7

Item No.	Designator	Part No.	Description	Item No.	Designator	Part No.	Description
6	R5	174868	7/16" x 68"	16	40 Meter Insulator	460316	Element Insulator
7	DE4 & R4	190006	5/8" x 26"	45	Caplug	455625	Caplug, Black, 2"
8	DE3 & R3	191007	7/8" x 55"	49	DE5	171533	7/16" x 58"
9	DE2 & R2	878241	1" x 51"	50	Boom Tube	171538	2" x 83"
10	DE1 & R1	878242	1 1/4" x 83"	51	Boom Tube	171539	2" x 54 3/4"

Figure 9
Overall View of Antenna

Driven Element and Reflector Linear-loading Wire Assembly

Select the parts listed in Figure 10. Refer to Figures 10, 11, and 12 for assistance in assembling and identification of the linear-loading wire assembly. Start assembling the linear-loading wire section (LLW) to the elements, beginning at the 40 meter insulator.

The 7/8" tubing clamp (Item 42) as shown in Detail A of Figure 11 should be positioned as close as possible to the 40 meter insulator. Other clamps and wire positions will depend upon the final assembly of the linear loading wires.

Repeat this instruction for each half of the driven and reflector element.

Tighten all bolts securely!

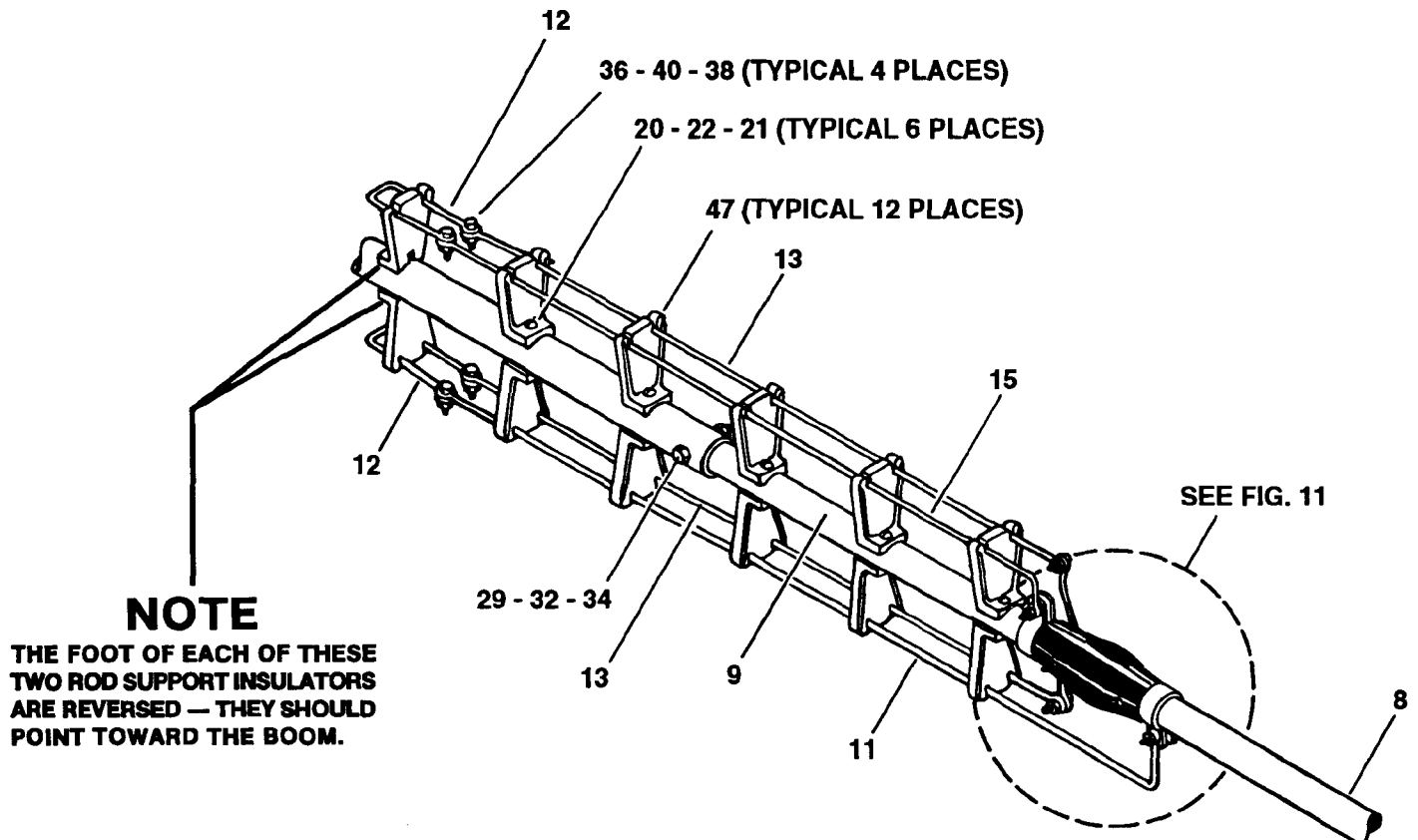

Item No.	Description
8	Tube, Element, DE3 and R3, 7/8" x 55"
9	Tube, Element, DE2 and R2, 1" x 51"
11	"Hairpin", LLW1, 69"
12	"Hairpin", LLW2, 28"
13	"Hairpin", LLW3, 63 1/2"
15	"Hairpin", LLW5, 63 1/2"
20	Bolt, round head, #6 - 32 x 2"
21	Nut, hex, #6 - 32

Item No.	Description
22	
29	Lockwasher, internal, #6
32	
34	Bolt, hex head, 1/4" - 20 x 1 1/2"
36	Lockwasher, internal, 1/4" - 20
38	Nut, hex, 1/4" - 20
40	Bolt, hex head, #10 - 24 x
47	1/2 Nut, hex, #10 - 24
	Lockwasher, internal, #10
	Insulator, Rod Support

Figure 10 Linear-Loading Wire Assembly

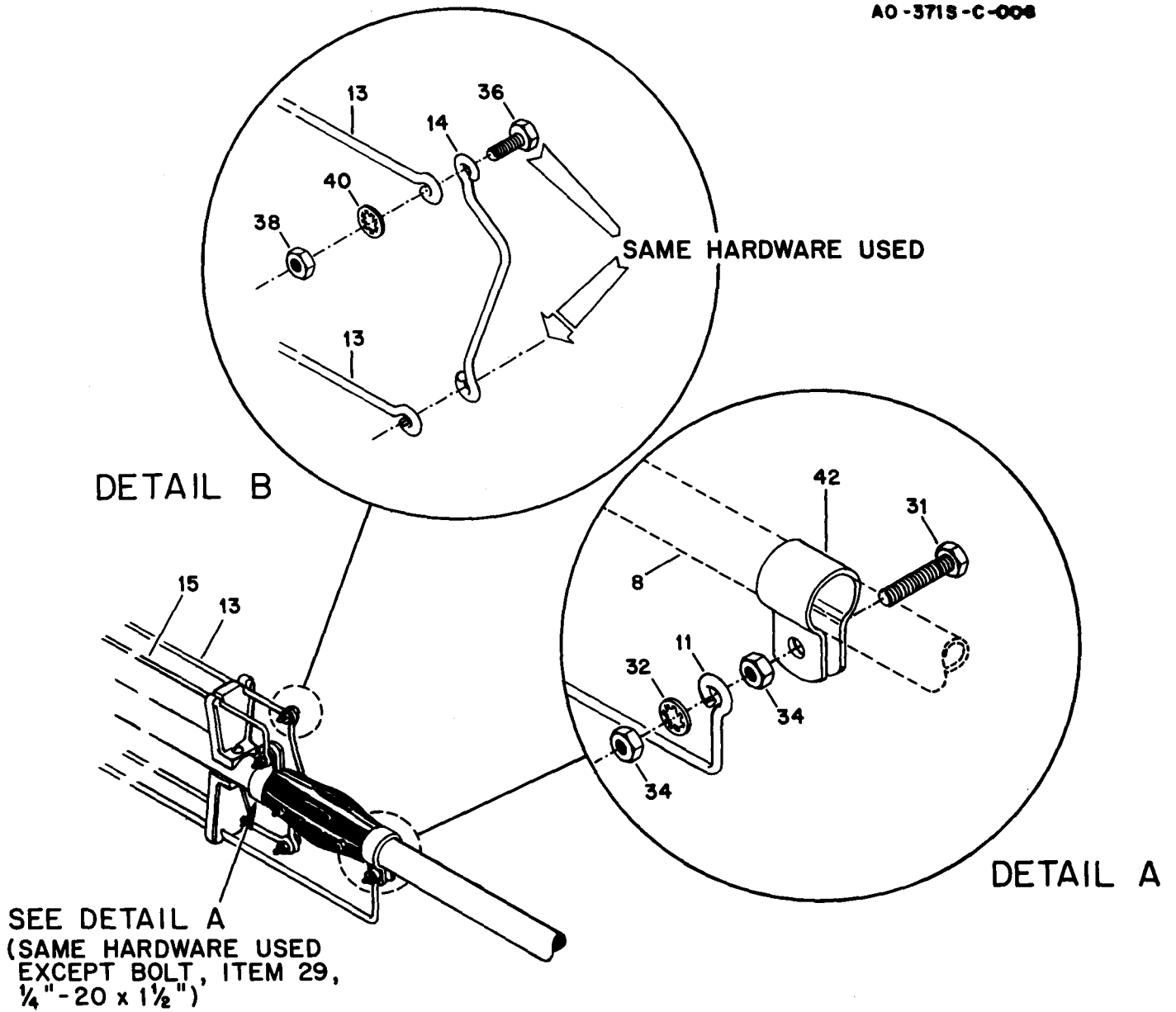

Item No.	Description
8 11	Tube, Element DE3 and R3, 7/8" x 55"
13	"Hairpin", LLW1, 69"
14	"Hairpin", LLW3, 63 1/2"
15	"Hairpin", LLW4, 31 1/2"
31	"Hairpin", LLW5, 63 1/2"
	Bolt, hex head, 1/4" - 20 x 1 1/4"

Item No.	Description
32	Lockwasher, internal, 1/4" -
34	Nut, hex, 1/4" - 20
36	Bolt, hex head, #10 - 24 x
38	Nut, hex, #10 - 24
40	Lockwasher, internal, #10
42	Clamp, Tubing, 7/8"

Figure 11 Attachment of Linear-Loading Wire Assembly Near Insulator

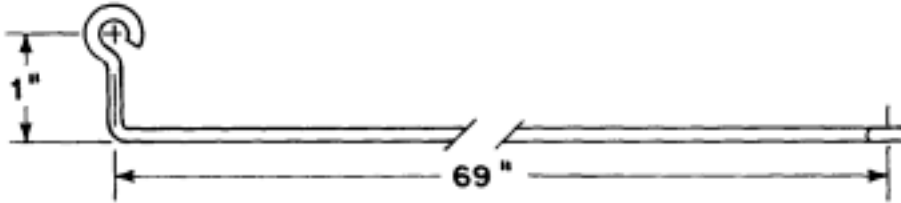

Item No. 11 - PN 171283 - "Hairpin", LLW1

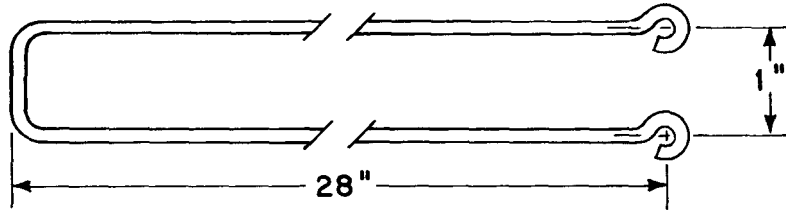

Item No. 12 - PN 171284 - "Hairpin", LLW2

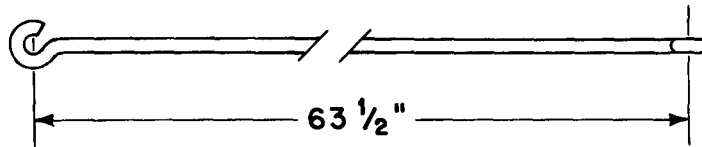

Item No. 13 - PN 17185 - "Hairpin", LLW3

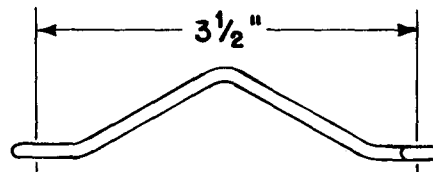

Item No. 14 - PN 171434 - "Hairpin", LLW4

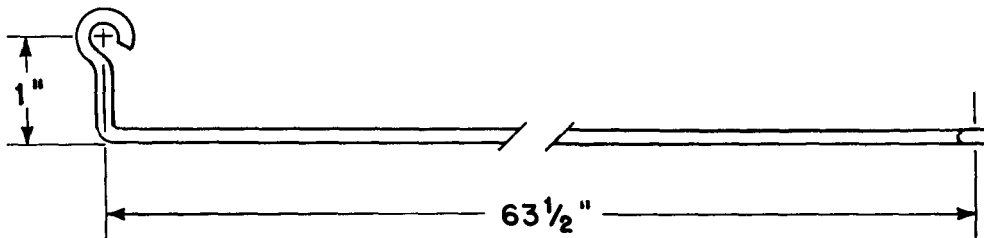

Item No. 15 - PN 171435 - "Hairpin", LLW5

Figure 12
Identification of Linear-Loading Wires (LLW)

Beta Match Assembly

AO-3725-A-

Select the parts listed in Figure 13 and Detail A and assemble them as shown. The beta shorting clamp should be flush with the ends of the beta rods. After attaching your coax cable to the feedpoint, tighten all hardware securely.

NOTE: Do Not allow the beta rods to touch the element-to-boom bracket.

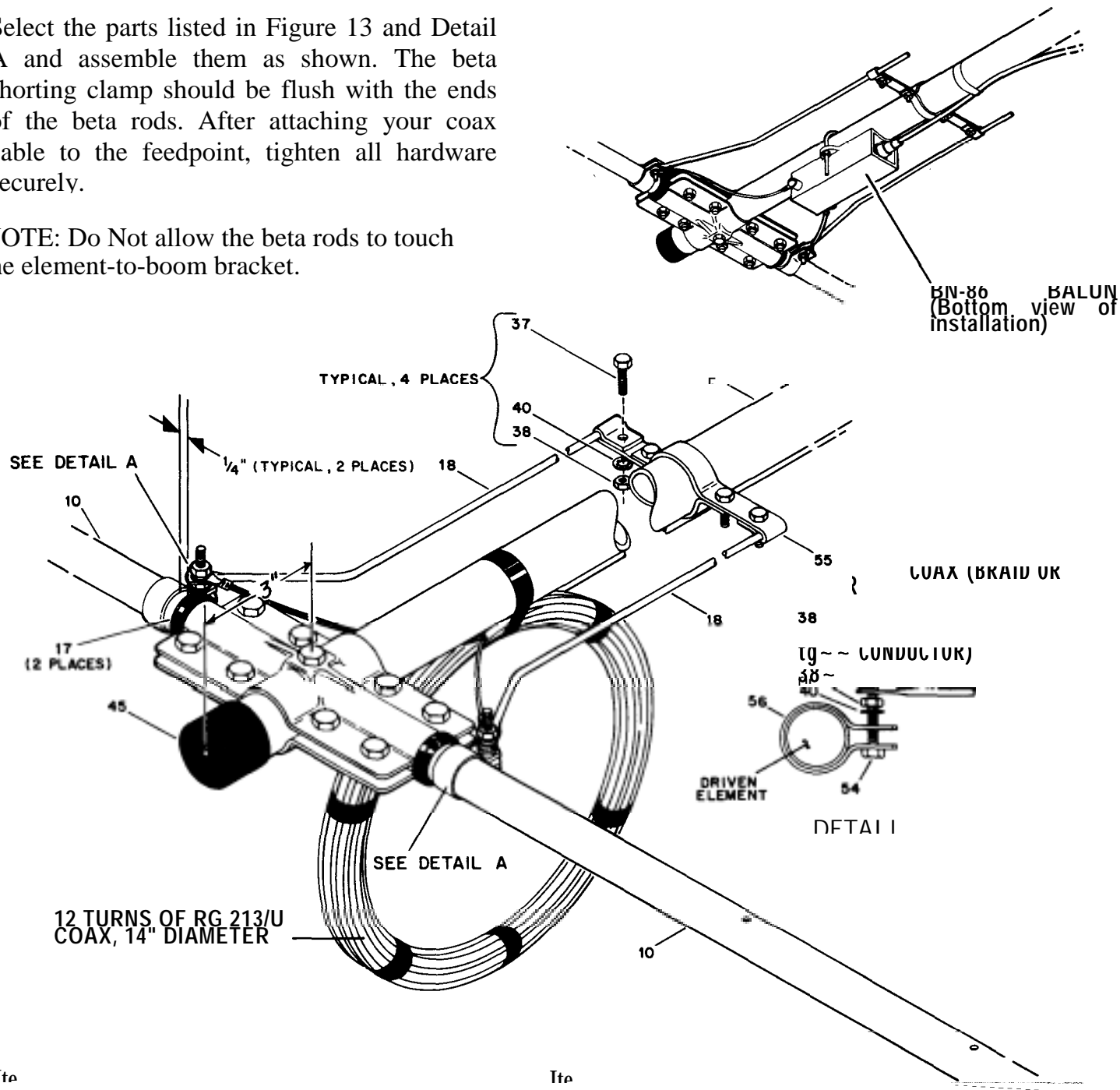

Item No.	Description
10	Tube, Element, DEJ and R1, 1 1/4" x 83"
17	Insulator, Element, DE1
18	Beta Rod, 1/4" x 72"
37	Bolt, hex head #10 - 24 x 1"
38	Nut, hex, #10 - 24
40	Lockwasher, internal, #10

Item No.	Description
45	Caplug, black, 2"
50	Tube, Boom, 2" x 83"
54	Bolt, hex head, #10 - 24 x
55	Clamp, Beta Shorting
56	Clamp, Tubing, 1 1/4"

Figure 13 Beta Match Assembly

Lightning

For proper lightning protection you must ground your antenna supporting structure. Grounding will ensure noise-free operation and low SWR. A proper ground consists of a 1/2" x 8' copper-clad steel ground rod driven into the ground approximately 12 inches away from the concrete tower base. Connect the tower to the ground rod using #8 copper wire and commercial noncorrosive ground clamps.

Attachment of

Strip your coaxial cable (maximum 7 inches) and install solder lugs (not supplied) and connect to the driven element as shown in Figure 13. An RF choke made from 12 turns of RG-213/u coax in a 14 inch diameter circle is recommended with a split coax feed.

An alternative is to use a Hy-Gain BN-86 or BN-4000 50 ohm balun for easy connection to your coax cable. "Pigtail" leads of #10 gauge stranded wire 7 inches long should be used from the balun to the tubing clamps.

Use a good quality 50 ohm coaxial transmission line such as Belden 8214 (foam) or Belden 8237, 8267 or 9251 (solid). Take extra care when soldering connectors to foam dielectric coaxial cable. Weather-proof all connectors, which will be exposed to rain or ice, with Coax-Seal© or another similar substance.

Attach the transmission line to the feedpoint and tighten the hardware securely. Tape the coax to the boom and mast to ensure good strain relief.

Boom Support Assembly

Select the 2 inch ID boom support clamps (Item No. 62) and the boom support straps (Item No. 61) and assemble on the boom 100 inches from the center of the boom-to-mast clamp as shown in Figure 14. Tighten the bolts securely.

Select the 20 foot boom support cable and cut into two equal lengths with a large pair of wire cutters. Attach one end of each cable to the boom support straps using the thimbles (Item No. 59) provided. See Figure 14. Attach the turnbuckles (Item No. 57) to the opposite ends of the cable as shown.

Measure the length of the assembled support cable and turnbuckle as shown. Install the 3/8" x 2" bolt, lockwasher and nut in each half so that they will be available after the antenna has been hoisted to the top of the tower. Also, tighten the turnbuckles so they will not vibrate loose. Route both cables along the boom and tape near the boom-to-mast bracket so they can be reached after the antenna has been mounted on the tower.

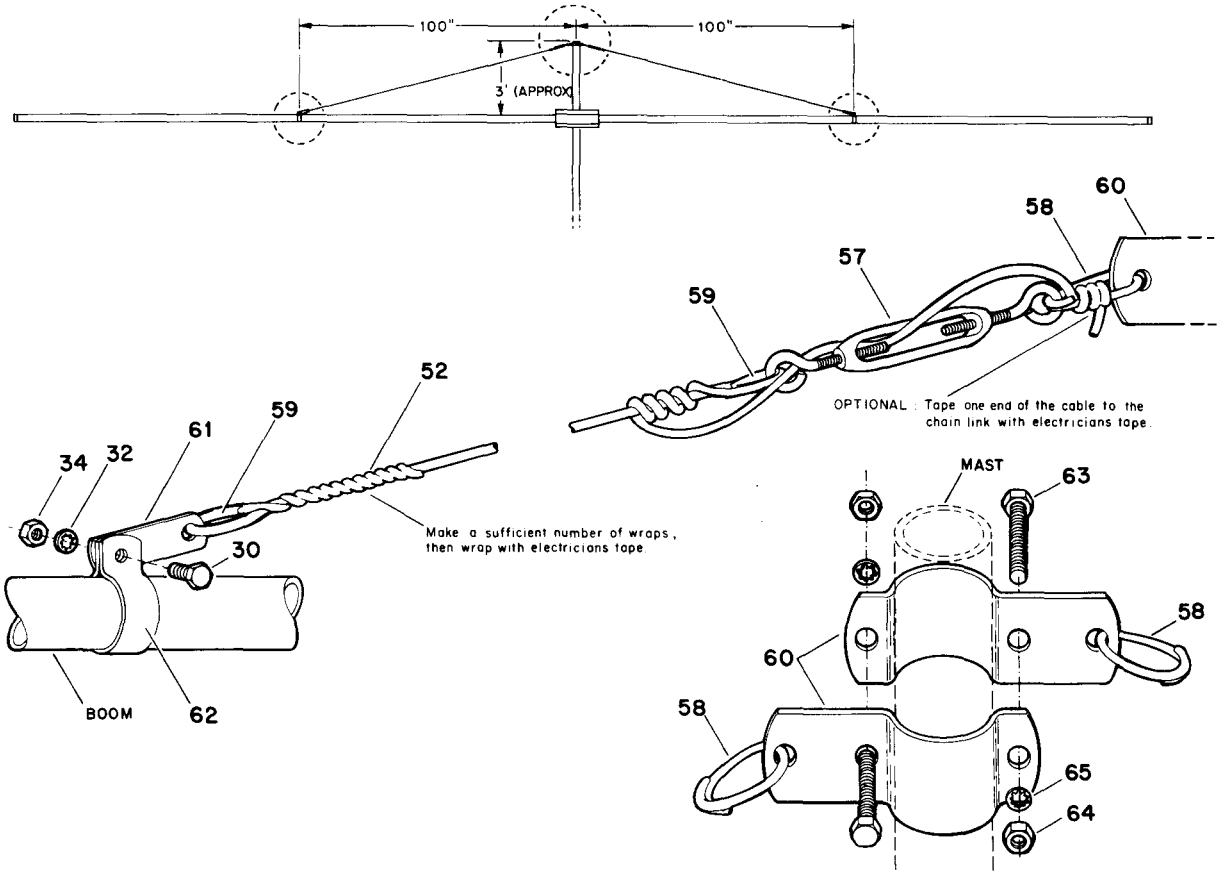

Item No	Description	Item No.	Description
32	Lockwasher, internal, 1/4" - 20	60	Mast Clamp, Boom Support, 15/8" I.D.
34	Nut, hex, 1/4" - 20	61	Strap, Boom Support
52	Cable, Boom Support, 1/8" x 20'	62	Clamp, Boom Support, 2" I.D.
57	Turnbuckle, Eye and Eye, 7/32" x 2"	63	Bolt, hex head, 3/8" - 16 x 2", tap
58	Chain Link, Open-End, 3/16"	64	Nut, hex, 3/8" - 16
59	Thimble, Wire Rope, 5/32"	65	Lockwasher, internal, 3/8"

Figure 14 Boom Support Assembly

CHAPTER 4 - INSTALLATION

Installation

Make sure **all** tubing clamps and anchor screws are securely tightened. Also, make sure all beta-match hardware is tightened securely and free of corrosion.

IMPORTANT: The Discoverer 7-2 is a fairly large and heavy antenna and requires some consideration as to how you are going to get it to the top of the tower. Thoroughly read this section before beginning to install your antenna.

Installation on a Crank-Up Tower

Crank the tower down completely or as low as it will go, and block all sections from moving by using a 2" x 4" piece of wood or a solid iron bar for heavier towers. The block should be inserted through the lattice structure before the tower is completely down, then the tower can be cranked down until the block takes the weight off the winch.

Use a ladder to reach the top of the tower. Never climb the lattice structure of any Crank-up Tower! Attach the mast to the tower and rotator. (The cast aluminum boom-to-mast bracket should be installed on the mast as shown in Figure 15.) Attach a gin pole to the tower to assist in lifting the Discoverer 7-2.

Attach the lifting rope to the balance point of the antenna. The lifting rope should be fed through the gin pole or other pulley arrangement attached to the tower. The other end should be at ground level, available to the ground crew for lifting. Guide ropes may be loosely looped over the boom ends and used by the ground crew to guide the antenna away from the tower and ladder. The guide rope's two loose ends should be held by the ground crew so that the guide rope can be retrieved.

Attaching the Antenna to the Mast

Assemble the two cast aluminum brackets (Item No. 1) on the mast at the desired height above your tower. Secure the two brackets together using the two (2) 5/16"-18 x 3" bolts, lockwashers, and nuts (Item Nos. 24, 27, & 26). You may wish to drill a 5/16" hole through the cast brackets' center hole and through the mast and secure using a 5/16"-18 x 4" bolt, lockwasher, and nut (Item Nos. 66, 27, & 26). This bolt will prevent the antenna from twisting on the mast in high winds. See Figure 1.

When the antenna reaches the mast bracket, the four (4) 5" bolts should be inserted through the holes in the mast bracket and secured using 5/16" - 18 lockwashers and nuts (Item Nos. 23, 27 and 26). Tighten all bolts securely. You may wish to use a deep-well socket set to tighten these bolts.

The boom support cables may now be untaped from the boom and attached to the mast. Loosen the turnbuckles and slide the entire assembly up the mast until the boom support wires are straight. Tighten the 3/8" - 16 bolts securely. Take up any slack in each wire with the turnbuckles, until the boom is level. When taut, tie off the turnbuckles. See Figure 14.

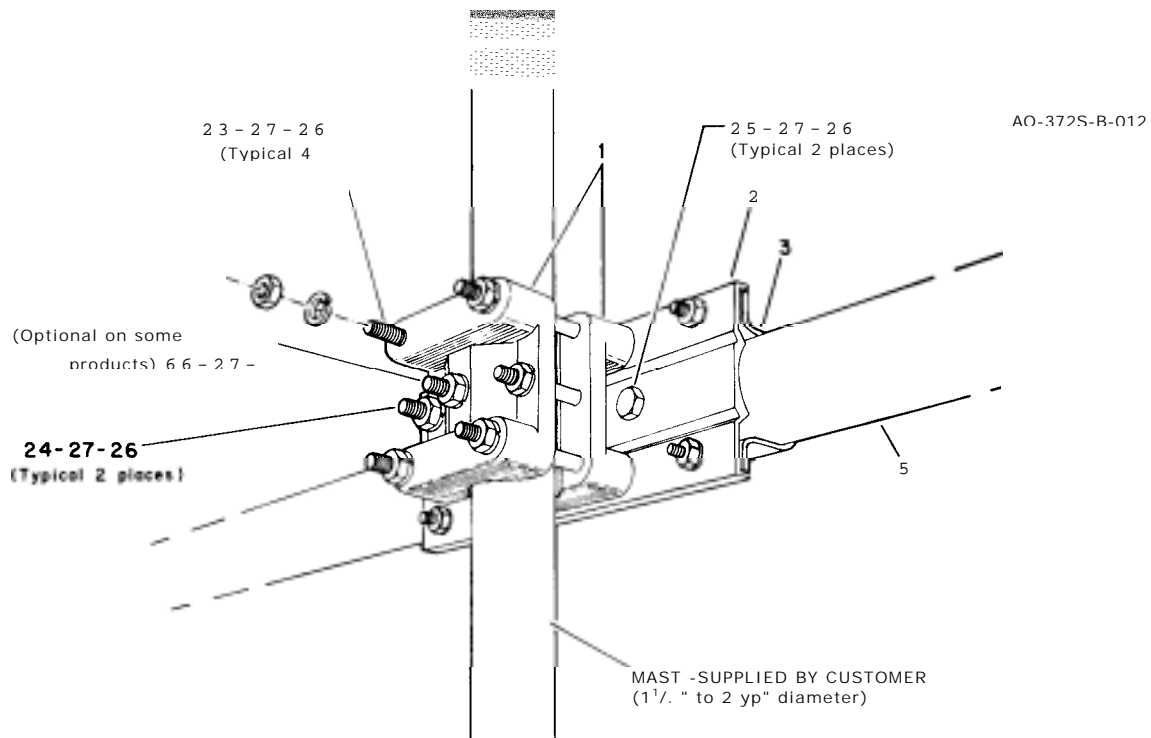

Ite No.	Description	Item No.	Description
1	Bracket, Cast Aluminum Mast	25	Bolt, hex head, 5/16" - 18 x 2 3/4"
2	Bracket, Casting-to-Boom	26	Nut, hex, 5/16" - 18
3	Clamp, Boom-to-Bracket	27	Lockwasher, split, 5/16"
23	Bolt, hex head, 5/16"-18 x "5	51	Tube, Boom, 2" x 54 3/4", swaged
24	Bolt, hex head, 5/16"-18 x 3"	66	Bolt, hex head, 5/16"-18 x 4"

Figure 15 Attaching Boom-to-Mast Bracket

Other Types of

When installing the Discoverer 7-2 on a guyed tower, you may wish to use a different guide system. If you have insulators on your guy wires, you will need to keep the antenna away from the guy wires as well as the tower. You may wish to use two ropes attached to the ground about 15 feet apart. These two ropes can then be used to slide the antenna on as it is also being lifted. The two ropes will need to be far enough from the tower base to allow some sag and still support the antenna away from the guy wires.

This completes your installation. Happy Dx'ing!

WARNING

Installation of this product near power lines is dangerous. For your safety follow the instructions.

CHAPTER 5 SERVICE / PARTS LIST

Service Information

If you are encounter technical problems and need assistance, you should contact Hy-Gain Customer Service Department.

All requests, inquires, warranty claims, or for ordering replacement parts, contact:

Hy-Gain

**308 Industrial Park Road
Starkville, Mississippi 39759 USA**
Phone: 662-323-9538
FAX: 662-323-6551

NOTE: Item Numbers may not necessarily be in numerical sequence and may appear more than one time, depending on how often a part is used or identical parts being placed in different parts packs.

Item No.	Part No.	Description	Qty
1	102734	Bracket, Cast Aluminum Mast.....	2
2	172735	Bracket, Casting-to-Boom	1
3	172732	Clamp, Boom-to-Bracket.....	1
4	165920	Bracket, Element-to-Boom, #14	2
5	850091	Penetrox®A-3	1
6	174868	Tube, Element, R5, 7/16" x 68"	2
7	190006	Tube, Element, DE4 and R4, 5/8" x 26"	4
8	191007	Tube, Element, DE3 and R3, 7/8" x 55"	4
9	878241	Tube, Element, DE2 and R2, 1" x 51"	4
10	878242	Tube, Element, DE1 and R1, 1 1/4" x 83"	4
11	171283	"Hairpin", LLW1, 69"	4
12	171284	"Hairpin", LLW2, 28"	8
13	171285	"Hairpin", LL W3, 63 1/2"	8
14	171434	"Hairpin", LLW4, 3 1/2"	4
15	171435	"Hairpin", LLW5, 63 1/2"	4
16	460316	Insulator, Element, 40 Meter.....	4
17	465833	Insulator, Element, DE.....	2
18	171439	Beta Rod, 1/4" x 72"	2
19		(Not Used)	

Parts List Continued

Item No.	Part No.	Description	Qty
48	165919	Bracket, Element-to-Boom, #13	2
49	171533	Tube, Element, DE5, 7/16" x 58"	2
50	171538	Tube, Boom, 2" x 83"	2
51	171539	Tube, Boom, 2" x 54 3/4", swaged	2
52	690181	Cable, Boom Support, 1/8" x 20'	1
	878245	Parts Pack 372S, Hardware, Stainless Steel	1
20	500143	Bolt, round head, #6 - 32 x 2"	26
21	555888	Nut, hex, #6 - 32	26
22	565889	Lockwasher, internal, #6.....	26
23	500349	Bolt, hex head, 5/16" - 18 x 5"	4
24	500392	Bolt, hex head, 5/16" - 18 x 3"	2
25	506968	Bolt, hex head, 5/16" - 18 x 2 3/4"	2
26	555747	Nut, hex, 5/16" - 18.....	9
27	564792	Lockwasher, split, 5/16"	9
28	500156	Bolt, hex head, 1/4" - 20 x 3/8"	6
29	504098	Bolt, hex head, 1/4" - 20 x 1 1/2"	8
30	505266	Bolt, hex head, 1/4" - 20 x 3/4"	20
31	506518	Bolt, hex head, 1/4" - 20 x 1 1/4"	4
53	505734	Bolt, hex head, 1/4" - 20 x 2 1/2"	2
32	562961	Lockwasher, internal, 1/4" - 20.....	46
33	551367	Nut, square, 1/4"	4
34	554099	Nut, hex, 1/4" - 20.....	44
35	500157	Bolt, hex head, #10 - 24 x 2"	8
36	500158	Bolt, hex head, #10 - 24 x 1/2"	26
37	504069	Bolt, hex head, #10 - 24 x 1"	4
54	500159	Bolt, hex head, #10 - 24 x 1 1/2"	2
38	554071	Nut, hex, #10 - 24	42
39	555693	Nut, square, #10 - 24.....	4
40	565697	Lockwasher, internal, #10.....	42
66	5142400	Bolt, hex head, 5/16" - 18 x 4"	1
	878246	Parts Pack 372S, Clamps	1
41		(Not Used)	
42	169339	Clamp, Tubing, 7/8"	8
43	358756	Clamp #6 Tubing	8
44		(Not Used)	
55	163371	Clamp Beta Shorting.....	2
56	171333	Clamp, Tubing, 1 1/4"	2
	878247	Parts Pack 372S, Insulators	1
45	455625	Caplug, black 2"	2
46	455644	Caplug, black, 7/16"	4
47	463642	Insulator, Rod Support.....	48

Item No.	Part No.	Description	Qty
	878248	Parts Pack 372S, Boom Support	1
57	351243	Turnbuckle, Eye and Eye, 7/32" x 2"	2
58	351244	Chain Link, Open-End, 3/16"	2
59	358731	Thimble, Wire Rope, 5/32" Stainless Steel.....	4
60	381100	Mast Clamp, Boom Support, 1 5/8" I.D.....	2
61	378216	Strap, Boom Support, Stainless Steel.....	2
62	378208	Clamp, Boom Support, 2" I.D., Stainless Steel.....	2
63	500152	Bolt, hex head, tap, 3/8" - 16 x 2"	2
30	505266	Bolt, hex head, 1/4" - 20 x 3/4"	2
32	562961	Lockwasher, internal, 1/4"	2
34	554099	Nut, hex, 1/4" - 20.....	2
64	555694	Nut, hex, 3/8" - 16.....	2
65	565696	Lockwasher, internal, 3/8"	2

Converting American Measurements to Metric

Use this scale to identify lengths of bolts, diameters of tubes, etc. The American inch (") and foot (') can be converted to centimeters in this way.

$$1 \text{ inch (1")} = 2.54 \text{ cm}$$

$$1 \text{ foot (1')} = 30.48 \text{ cm}$$

$$\text{Example: } 42" \times 2.54 = 106.7 \text{ cm}$$

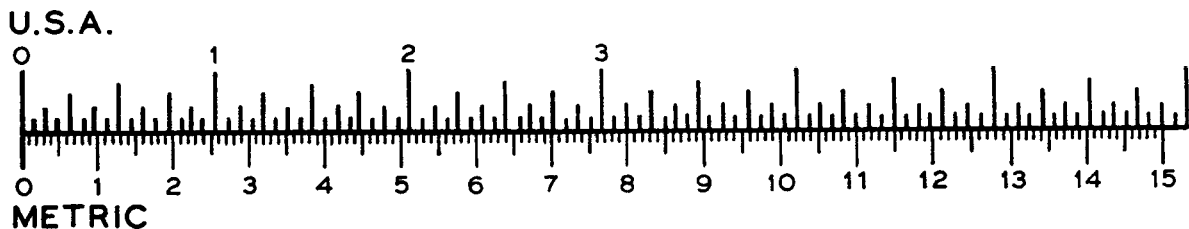

hy-gain® LIMITED

hy gain Warrants to the original owner of this product, if manufactured by *hy gain* and purchased from an authorized dealer or directly from *hy gain* to be free from defects in material and workmanship for a period of 12 months for rotator products and 24 months for antenna products from date of purchase provided the following terms of this warranty are satisfied.

1. The purchaser must retain the dated proof-of-purchase (bill of sale, canceled check, credit card or money order receipt, etc.) describing the product to establish the validity of the warranty claim and submit the original or machine reproduction of such proof-of-purchase to *hy-gain* at the time of warranty service *hy-gain* shall have the discretion to deny warranty without dated proof-of-purchase. Any evidence of alteration, erasure, or forgery shall be cause to void any and all warranty terms immediately.

2. *hygain* agrees to repair or replace at *by gain's* option without charge to the original owner any defective product under warranty, provided the product is returned postage prepaid to *hygain* with a personal check, cashiers check, or money order for \$8.00 covering postage and handling.

3. Under no circumstances is *hygain* liable for consequential damages to person or property by the use of any *hygain* products.

4. Out-of-warranty Service: *hygain* will repair any out-of-warranty product provided the unit is shipped prepaid. All repaired units will be shipped COD to the owner. Repair charges will be added to the COD fee unless other arrangements are made.

5. This warranty is given in lieu of any other warranty expressed or

6. *hygain* reserves the right to make changes or improvements in design or manufacture without incurring any obligation to install such changes upon any of the products previously manufactured.

7. All *hy-gain* products to be serviced in-warranty or out-of-warranty should addressed to *hvgain*. 308 Industrial Park Road.
Mississippi 39759, USA and must be accompanied by a letter describing the problem in detail along with a copy of your dated proof-of-purchase.

8. This warranty gives you specific rights, and you may also have other rights which vary from state to state.