



308 Industrial Park Road

Starkville, MS 39759 USA Ph:
(662) 323-9538 FAX: (662) 323-6551

LJ-203BA

Long John MonoBander
3-Element 20-Meter Beam

INSTRUCTION MANUAL

General Description

The Hy-Gain 203BA-S is an optimum spaced, three-element, 20-meter beam. A beta match insures maximum transfer of energy from the feedline to the antenna. The Model 203BA-S is recommended to fit a 2" to 2 1/2" O.D. mast and can be rotated with the CD-4511 or Ham IV rotators. The 203BA-S now includes stainless steel hardware for all electrical and most mechanical connections.

Preparation for Assembly

Please read all the installation instructions and study the illustrations before beginning the antenna assembly.

FOR OVERSEAS CUSTOMERS: If you use the Metric System, see the American-to-Metric conversion table in the rear of this manual. Most illustrations in this manual will provide both American and Metric Dimensions.

When unpacking your antenna, check inside of all tubing for small parts and elements. To conserve space, these smaller articles are sometimes put inside larger pieces. Check all parts against the parts list in the rear of this manual to ensure no parts are missing.

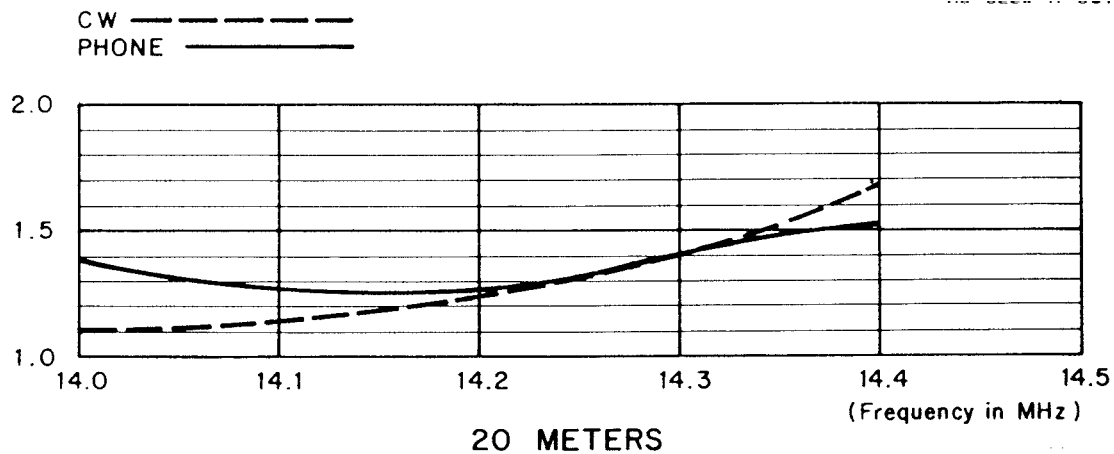

Figure 1
VSWR Chart

Specifications

Electrical

Input Impedance.....	50 ohms
*Forward Gain, average.....	7.15 dBi (5.0 dBd)
*Front-to-Back Ratio, all lobes	23 dB maximum
Maximum Power Input.....	maximum legal
VSWR at Resonance.....	less than 1.5:1
Lightning Protection.....	DC ground
2:1 VSWR Bandwidth.....	500 KHz minimum

Mechanical

Boom Length.....	16 ft. 6 in. (5.02 m)
Boom Diameter.....	2 in. (5.08 cm)
Longest Element.....	37' 1" (11.30 m)
Maximum Wind Survival.....	80 mph (128.7 kmph)
Net Weight.....	32 lbs. (14.51 kg)
Accepts Mast.....	1 1/4" to 2 1/2" (3.2 cm to 6.3 cm)
Wind Surface Area.....	5.38 sq. ft. (0.50 m ²)
Wind Load @ (80 mph) (128.7 kmph).....	138 lbs (62.59 kg)
Turning Radius	20.1 ft (6.126 m)

*Gain and Front-to-Back verified by computer modeling with the MININEC 3 and YO© computer codes and radiation pattern measurements of full size antennas on Hy-Gain's antenna test range.

All tubing supplied with the Model 203BA-S is taper-swaged and designed to telescope together. It is held in place with compression clamps. Make all measurements as accurate as possible using the dimensions given in this manual for best results from your antenna.

Assembly of the Boom

Select the cast aluminum brackets, casting-to-boom bracket and boom-to-bracket clamp and loosely assemble as shown in Figure 2. The brackets must be loose to facilitate assembly of the boom.

Select the two 45" boom sections (2" diameter tubing) and slip the unswaged end of each into the boom-to-mast bracket. Line up the holes in the boom with the holes in the boom-to-mast bracket and secure using the two (2) 5/16"-18 x 2 3/4" bolts, nuts and lockwashers (Item Nos. 34, 37 & 39) provided.

Slip the remaining boom sections (Item 4, 2" x 57") over the swaged end of the assembled boom sections (Item 5, 2" x 45") and secure the 1/4" x 2 1/2" bolts (Item 30), nuts (Item 33) and lockwashers (Item 31).

Item No.	Description
1	Bracket, cast aluminum
2	Bracket, casting-to-boom
3	Clamp, boom-to-bracket
5	Tube, aluminum, 2" x 45"
28	Bolt, hex head, 1/4" - 20 x 3/4"
32	Nut, square, 1/4" - 20
33	Nut, hex 1/4" - 20
34	Bolt, hex head, 5/16" - 18 x 2 3/4"
35	Bolt, hex head, 5/16" - 18 x 3 1/2"
36	Bolt, hex head, 5/16" - 18 x 5"
37	Lockwasher, split, 5/16"
39	Nut, hex, 5/16" - 18

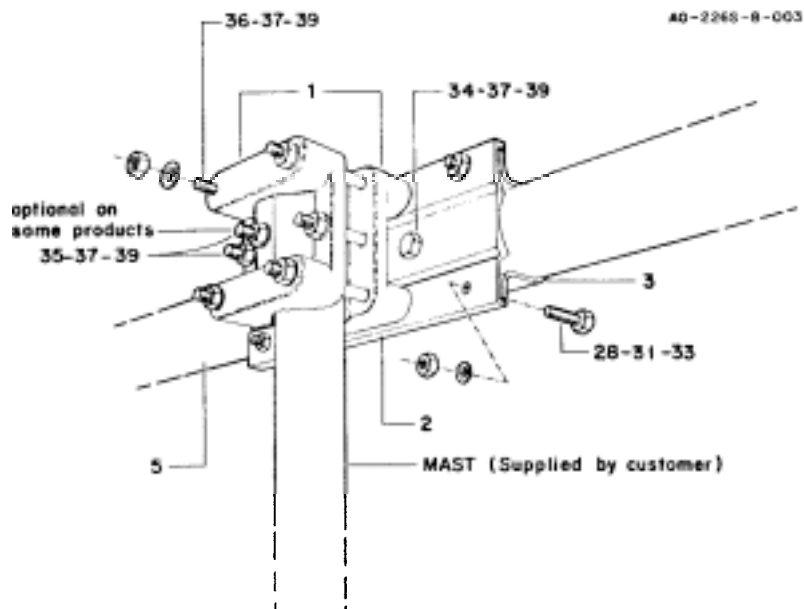
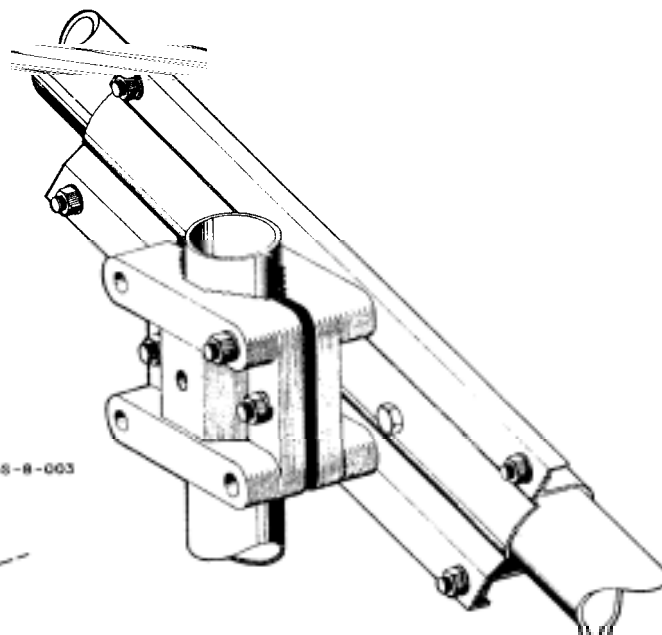

Figure 2 Boom-To-Mast Bracket Assembly

Tools: The following tools are required for easy assembly of the 203BA-S Beam:

Qty	Tool Type
1	Tape measure, 12 ft.
1	Nut Driver, 1/2 in.
1	Nut Driver, 7/16 in.
1	Nut Driver, 3/8 in.
1	Nut Driver, 11/32 in.

NOTE: One end of each of the 2" x 45" boom sections has a small hole drilled approximately 28 3/4" from the boom-to-mast bracket. Both holes must be positioned so they are facing down (earthward) when the boom is assembled.

One hole will be used for attaching the beta match in a later step. This end of the boom will be known as the reflector end. Refer to Figure 5.

DO NOT tighten all the screws in the boom-to-mast bracket, at this time. The cast brackets must be loose for attaching to the mast in a later step.

Compression Clamps

To save time, loosely assemble all of the compression clamps and their appropriate hardware before beginning further installation of the antenna. See Figure 3. When installing the clamps, place the clamp near the tube end with the open side even with the slot in the tube.

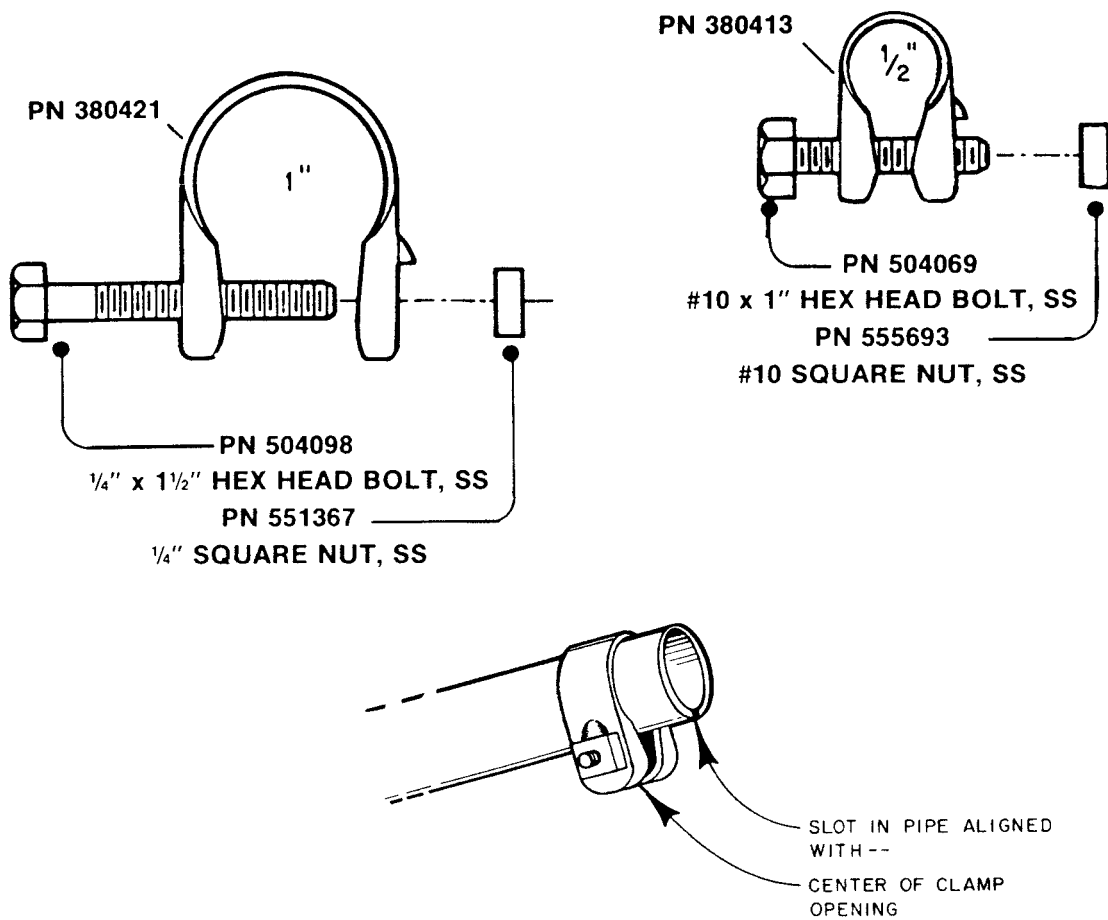

Figure 3
Compression Clamps

Tighten the clamp until the inner tube cannot be turned in the outer tube. DO NOT tighten the compression clamps until instructed to do so.

You may wish to preform the clamps to the tubing for easier assembly. Spread the ears of the clamp apart slightly and slip the clamp onto the appropriate size of tubing. Squeeze the ears of the clamp together using standard hand pliers. Release and slide the clamp off the end of the tubing. Install the appropriate bolt and nut onto each clamp.

NOTE: The use of a few drops of heavy motor oil or grease on the threads of the stainless steel bolts will prevent them from galling and seizing up when tightened.

Assembly of the Reflector

Select a set of small sized element-to-boom brackets (marked with a No. 13) and *LOOSELY* assemble on the reflector end of the boom. Assemble the bracket approximately 2 3/4" from the end of the boom to the center of the bracket. Refer to Figures 4 and 5.

NOTE: The following steps will be in singular form. Assemble both side's in the same manner.

Select the r1 section of tubing (1 1/4" x 72"). Slip the unswaged end of the R1 section into the element-to-boom bracket assembled on the boom. Tighten the bolts (Item Nos. 28, 31 & 33) to hold the element securely but DO NOT *TIGHTEN THE ANCHOR BOLTS (ITEMNO. 27) AT THIS TIME.*

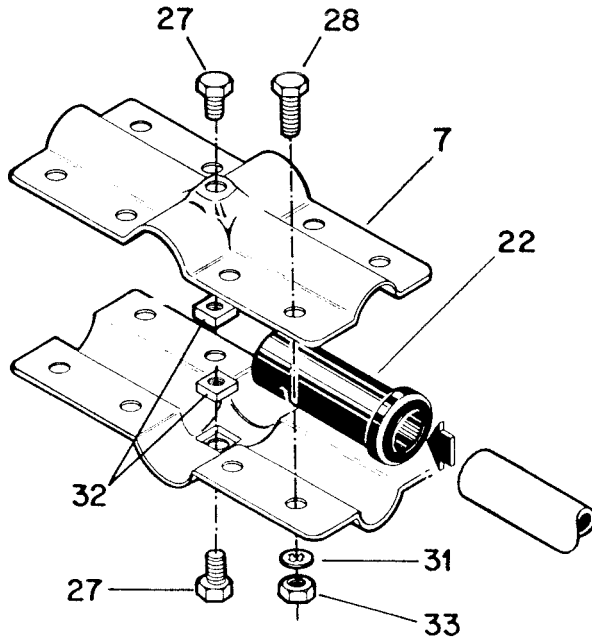

Driven Element

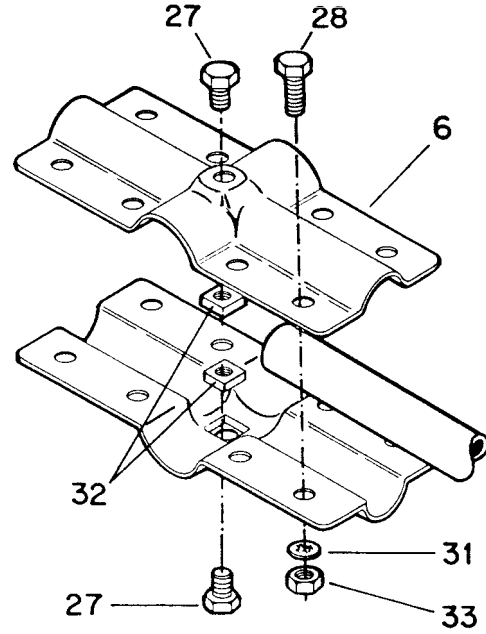

**Reflector Element
and Director Element**

Item No.	Description
6	Bracket, Element-To-Boom, #13
7	Bracket, Element-To-Boom, #14
22	Insulator (for driven element)
27	Bolt, hex head, 1/4" - 20 x 3/8" (anchor bolts)

**Figure 4 Element-To-Boom Bracket
Assembly**

Check to see that the Reflector Element will lie parallel to the earth when the antenna is mounted on the mast. To do this observe the position of the Reflector Element with respect to the boom-to-mast bracket, then adjust the Reflector Element accordingly. Recheck the 2 3/4" measurement from the end of the boom to the center of the bracket then tighten the anchor bolts **SECURELY!**

Select a 1" compression clamp and its associated bolt and square nut and assemblies as shown in Figure 3.

Slip the assembled compression clamp over the end of the r1 section. Select the R2 section (7/8" x 84") and slip the unswaged end into the R1 section.

Measure 81" from the end of the RI to the end of the R2 as shown in Figure 5, then tighten the compression clamps **SECURELY!**

Assemble a 1/2" compression clamp as shown in Figure 4. Slip the assembled clamp over the end of the R2 section. Select the R3 section (7/16" x 71") and slip it into the R2 section.

Measure 68 1/2" from the end of the R2 section to the end of the R3 section. Tighten the compression clamp **SECURELY!**

Referring to Figure 5, carefully recheck all your measurements, then tighten all compression clamps **SECURELY!**

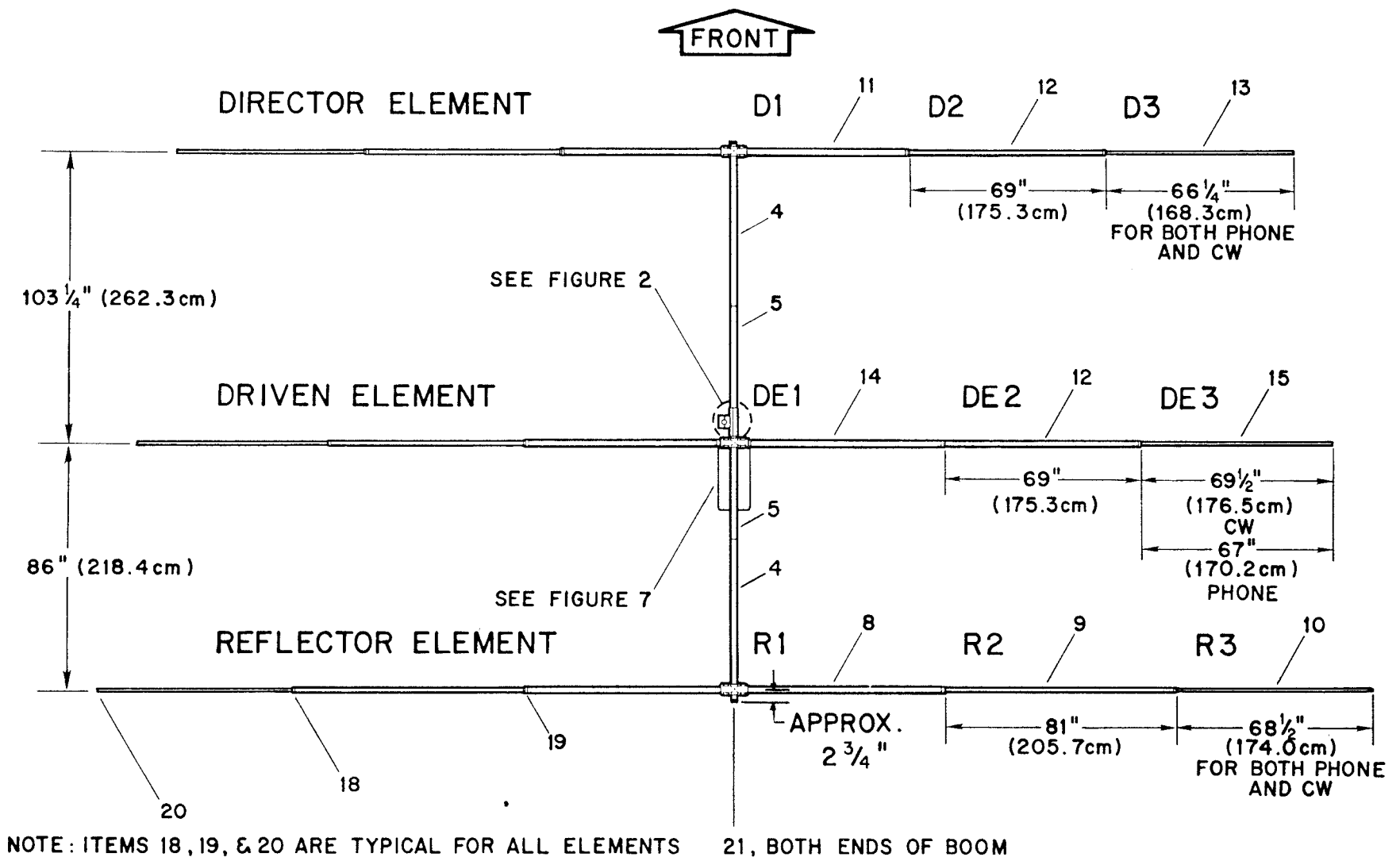

Item No.	Description	Item No.	Description
4	Tube, aluminum, 2" x 57"	13	Tube, aluminum, 7/16" x 72", DE3
5	Tube, aluminum, 2" x 45"	14	Tube, aluminum, 1 1/4" x 72", swaged, DE1
8	Tube, aluminum, 1 1/4" x 72", swaged, R1	15	Tube, aluminum, 7/16" x 72", DE3
9	Tube, aluminum, 7/8" x 84", swaged, R2	18	Clamp, compression, 1/2"
10	Tube, aluminum, 7/16" x 71", R3	19	Clamp, compression, 1"
11	Tube, aluminum, 1 1/4" x 60", swaged, D1	20	Caplug, 7/16", with hole (for element ends)
12	Tube aluminum, 7/8" x 72", swaged, D2 x DE	21	Caplug, 2", (for boom ends)

Figure 5 Overall View of
Assembly

Assembly of the Driven Element

Select the set of large sized element-to-boom brackets (marked with a No. 14) and **LOOSELY** assemble on the boom 86" from the center of the Reflector bracket to the center of the Driven Element bracket. Refer to Figures 4 and 5.

Select the DE1 section (1 1/4" x 72"). Slip a Driven Element Insulator (found in the parts pack) on the unswaged end of the DE1 section. Now slip the insulated end of the DE1 into the bracket assembled on the boom. (See Figure 4, "Driven Element Detail").

There is a small hole drilled near the Driven Element insulator and it must be positioned so it is facing down (earthward). This hole will be used to attach the Beta Match and feedline in a later step. Tighten the bolts to hold the element securely but **DO NOT TIGHTEN THE ANCHOR BOLTS 9 T THIS TIME.**

Check to see that the Driven Element will lie in the same plane as the Reflector element already installed. Carefully recheck the 86" measurement from the center of the Reflector bracket to the center of the Driven Element bracket then tighten the anchor bolts **SECURELY!**

Assemble a 1" compression clamp as shown in Figure 4. Slip the assembled clamp over the end of the DE1.

Select the DE section (7/8" x 72") and slip the unswaged end into the DE1 section. Measure 69" from the end of the DE1 then tighten the compression clamp **SECURELY!**

Assemble a 1/2" compression clamp as shown in Figure 3. Slip the assembled clamp over the end of the DE2.

Select the DE3 section (7/16' x 72") and slip it into the DE2 section. Determine at this time which mode of transmission you will use, either Phone or CW. Measure the dimension of the DE3 for your mode of transmission as shown in Figure 5. Tighten the compression clamp **SECURELY!**

Carefully recheck all measurements then tighten the compression clamps **SECURELY!**

Assembly of the Beta Match

Select the two Beta Match rods and secure to the bottom of the boom using the predrilled hole as shown in Figure 6. Secure with a # 10-24 x 5/8" self-tapping screw (Item No. 23).

Attach the other ends of the Beta Match to the predrilled holes in the Driven Element. **DO NOT** tighten the self-tapping screws in the Driven Element; they will also be used to connect the feedline in a later step.

NOTE: If the holes do not line up perfectly, loosen the anchor screws in the Driven Element bracket and move it just enough to line up the holes. Then retighten the anchor bolts after making certain the Driven Element still lies in the same plane as the Reflector Element.

AO-0226-A-001

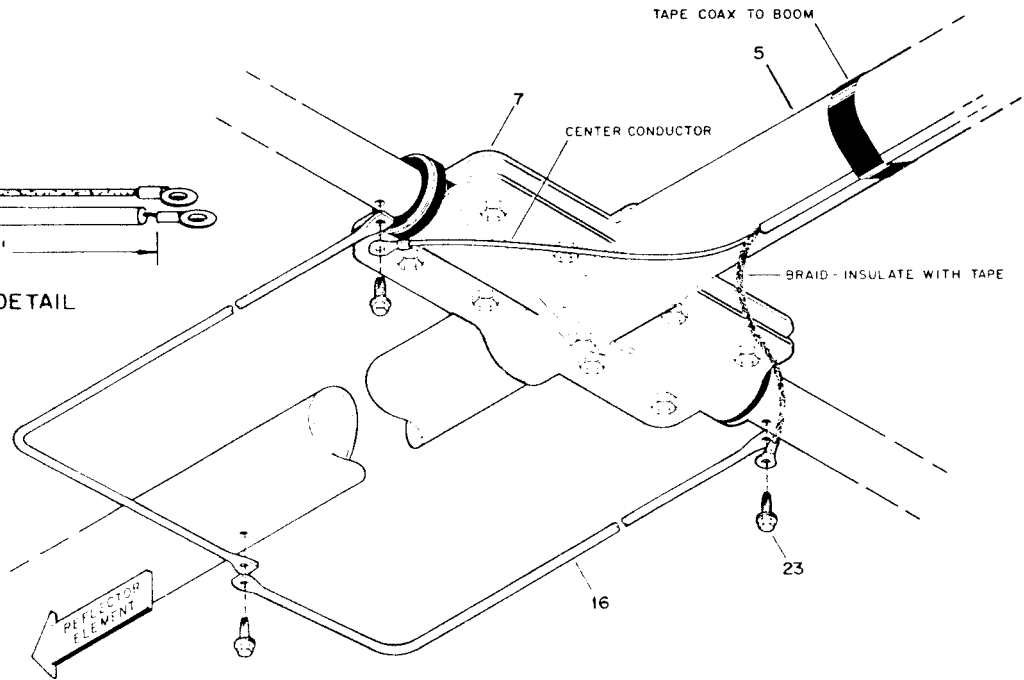
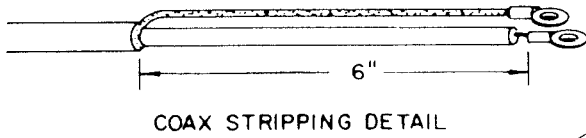

Item No.	Description
5	Tube, aluminum, 2" x 45"
7	Bracket, Element-to-Boom, #14
16	Beta Rod
23	Screw, self tapping, #10-24 x 5/8"

Figure 6 Beta Match Assembly

Assembly of the Director

Select the remaining set of element-to-boom brackets (marked with a No. 13) and *LOOSELY* assemble on the boom 103 1/4" from the center of the Driven Element bracket to the center of the Director bracket. Refer to Figures 4 and _5.

Select the D1 section (1 1/4" x 60"). Slip the unswaged end of the D1 section (1 1/4" x 60") into the bracket assembled on the boom. Tighten the screws to hold the element securely but **DO NOT TIGHTEN THE ANCHOR BOLTS AT THIS TIME**

Make certain that the Director will lie in the same place as the other elements and carefully recheck the 103 1/4" measurement from the center of the Driven Element bracket to the center of the Director bracket. Now tighten the anchor bolts **SECURELY!**

Assemble a 1' compression clamp as shown in Figure 3. Slip the assembled clamp over the end of the D1.

Select the D2 section (7/8" x 72") and slip the unswaged end into the D1 section. Measure 69" from the end of the D1 to the end of the D2 then tighten the compression clamp **SECURELY!**

Assemble a 1/2" compression clamp as shown in Figure 3. Slip the assembled clamp over the end of the D2 about 1".

Select the D3 section (7/16" x 68") and slip it into the D2 section. Measure 66 1/4" from the end of the D2 to the end of the D3 then tighten the compression clamps **SECURELY!**

Carefully recheck all dimensions then tighten the compression clamps **SECURELY!**

Rope Dampening Installation

Select the rope end cut it into ten equal lengths of six feet. Slip a length of rope into the end of each element. With about a 1/2" of rope extending from the element end separate the fibers and fold them back over the element (refer to Figure 7). Now slip a 7/16" caplug over the element rope. The rope inside the element will prevent vibrations caused by low wind velocities.

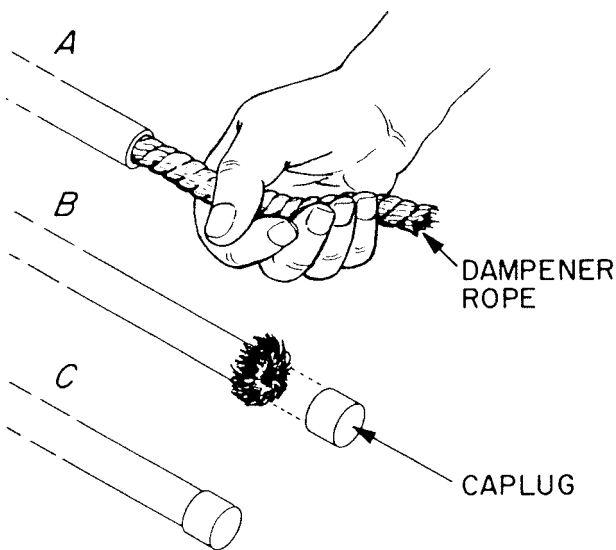

Figure 7 Rope Dampening Installation

Final Assembly

Place a 2" caplug on each end of the boom. Place 7/16" caplugs on the end of each element.

Strip your coaxial feedline (RG-213/u recommended) as shown in the detail in Figure 6 and attach solder lugs (not supplied). Attach the coax to the Driven Element and Beta Match as shown in Figure 6. Tighten the self-tapping screws **SECURELY!**

Weatherproof the connection using Coax-Seal or a similar substance. Also, weatherproof the coax where the conductors leave the protective covering. This will prevent water from entering and ruining the cable.

Securely tape the coax to boom using weatherproof tape.

A BN-86 balun may be used to attach the coaxial cable to the driven element.

Coax-Seal® is a registered trademark of Universal Electronics, Inc.

Installing the Antenna

There are two methods of installing the antenna. Decide ahead of time which method you will use.

Method 1 - Completely assemble the antenna on the ground, then hoist it into position as shown in Figure 8.

Method 2 - Assemble the antenna on the ground in halves, then hoist each half to the top of the tower and assemble it in the boom-to-mast bracket on the tower.

WARNING: When installing your system, take extreme care to avoid any accidental contact with power lines or overhead obstructions. Failure to exercise this care could result in serious or fatal injury.

Mount the antenna on your mast using one of the suggested methods. Tighten all bolts in the boom-to-mast bracket securely.

There is one hole left in the boom-to-mast bracket, which is [used to](#) pin the antenna to the mast (see Figure 2). Drill a 5/26" hole in the mast corresponding to the hole in the bracket. Pin the bracket to the mast using the 5/26" - 18 x 3 1/2" bolt (Item No.35) in the parts pack.

Securely tape the feedline to the mast and the antenna is ready for use.

WARNING
When installing your system, take extreme care to avoid any accidental contact with power lines or overhead obstructions. Failure to exercise this care could result in serious or fatal injury.

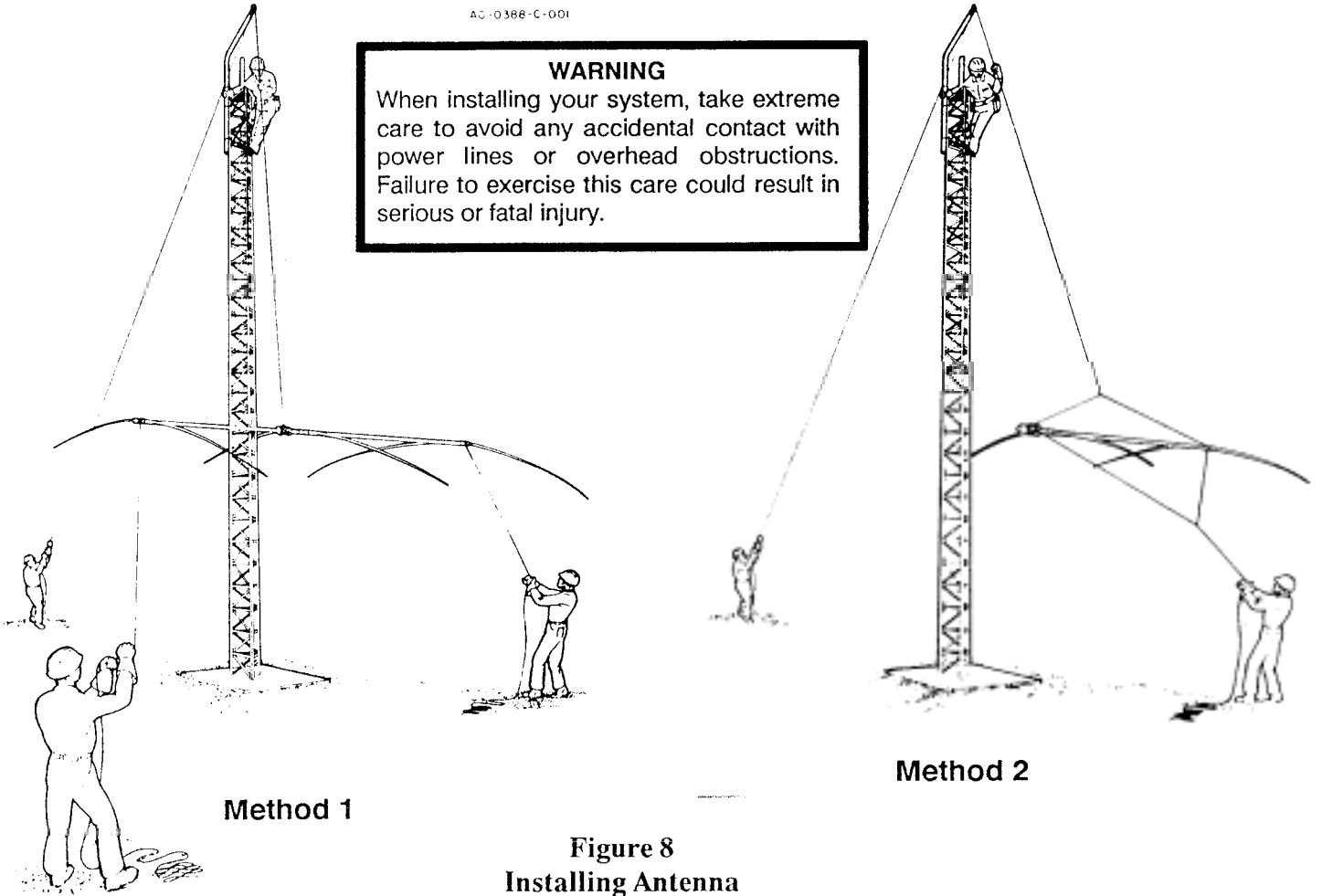

Method 1

Method 2

Figure 8
Installing Antenna

Lightning Protection

For lightning protection you must ground your antenna supporting structure. A proper ground consists of a 1/2" x 8' ground rod driven into the ground 12 inches from the base of your tower or mast. Connect the rod to the tower or mast using a copper strap or 12 gauge copper

Service Information

All requests, inquires, warranty claims, or for ordering replacement parts.

Hy-Gain
308 Industrial Park Road
Starkville, Mississippi 39759 USA
Phone: 662-323-9538
FAX: 662-323-6551

Use this scale to identify lengths of bolts, diameters of tubes, etc. The American inch (1") and foot (1') can be converted to centimeters in this way.

1 inch (1") = 2.54 cm 1 foot (1) = 30.48 cm Example: 42" x 2.54 = 106.7 cm

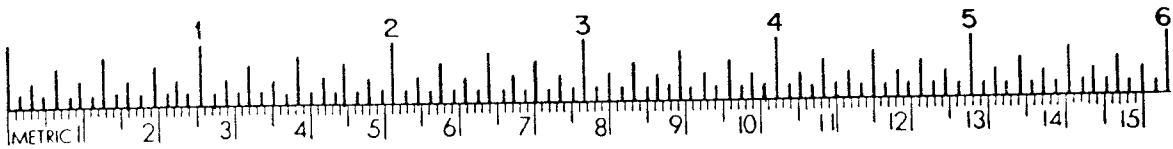

Item No.	Part No.	Description	Qty
1	102734	Bracket, cast aluminum	2
2	172735	Bracket, casting-to-boom	1
3	172732	Clamp, boom-to-bracket.....	1
4	170410	Tube, aluminum, 2" x 57".....	2
5	170048	Tube, aluminum, 2" x 45".....	2
6	16559	Bracket, element-to-boom, #13.....	4
7	165920	Bracket, element-to-boom, #14.....	2
8	190401	Tube, aluminum, 1 1/4" x 72", swaged, R1	2
9	174862	Tube, aluminum, 7/8" x 84", swaged, R2.....	2
10	175832	Tube, aluminum, 7/16" x 71", R3.....	2
11	190402	Tube, aluminum, 1 1/4" x 60", swaged, D1	2
12	190100	Tube, aluminum, 7/8" x 72", swaged, D2 & DE2.....	4
13	174868	Tube, aluminum, 7/16" x 68", D3.....	2
14	175117	Tube, aluminum, 1 1/4" x 72", swaged, DE1	2
15	175831	Tube, aluminum, 7/16" x 72", DE3.....	2
16	175121	Beta Rod.....	2.
17	691138	Rope, polyethylene, 5/32" x 12'.....	1
	871987	Parts Pack, 226S, Stainless Steel	1
18	380413	Clamp, compression, 1/2"	6
19	380421	Clamp, compression, 1"	6.
20	475639	Caplug, 7/16", with hole (for element ends)	6
21	455625	Caplug, 2" (for boom ends).....	2
22	465833	Insulator (for driven element)	2
23	526475	Screw, self-tapping, #10-24 x 5/8" (ZMI)	3
24	504069	Bolt, hex head, #10-24 x 1"	6
25	565697	Lockwasher, internal, #10.....	9
26	55693	Nut, square, #10-24.....	7.
27	500156	Bolt, hex head, 1/4"-20 x 3/8".....	6
28	505266	Bolt, hex head, 1/4"-20 x 3/4".....	28
29	504098	Bolt, hex head, 1/4"-20 x 1 1/2"	6
30	505734	Bolt, hex head, 1/4"-20 x 2 1/2"	2
31	562961	Lockwasher, internal, 1/4".....	37
32	551367	Nut, square, 1/4"-20.....	12
33	554099	Nut, hex, 1/4"-20	30
34	506968	Bolt, hex head, 5/16"-18 x 2 3/4"	2
35	500154	Bolt, hex head, 5/16"-18 x 3 1/2"	3
36	500153	Bolt, hex head, 5/16"-18 x 5".....	4
37	564792	Lockwasher, split, 5/16"	9
38	560024	Flatwasher, 5/16"	2.
39	555747	Nut, hex, 5/16"-18	9.



308 Industrial Park Road
 Starkville, MS 39759 USA Ph.
 (662) 323-9538 FAX: (662) 323-6551

Product Update

Compression Clamps

TUBING CLAMP ADDENDUM

GENERAL

The 1 1/4, 1, 3/4, 1/2 inch compression clamps and associated stainless steel hardware have been deleted from this product and have been replaced by stainless steel tubing (hose) clamps. Refer to the illustration and charts below for the proper size clamp to use.

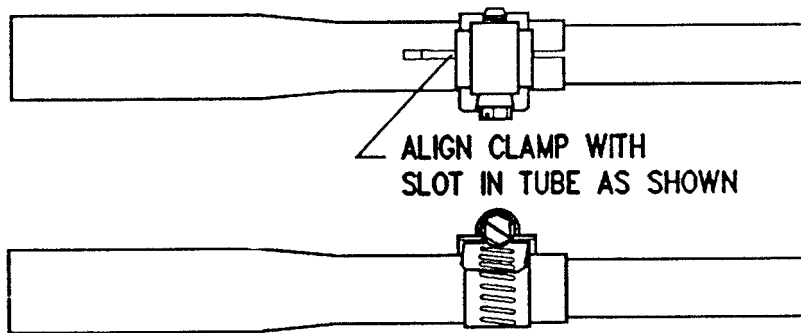

Part No.	Description	Fits Tubing Sizes	Replaces Compression Clamp P/N
358756	Clamp, Size #6 all stainless steel 5/16" hex head screw	7/16", 1/2",	380413
		5/8" and 3/4"	380420

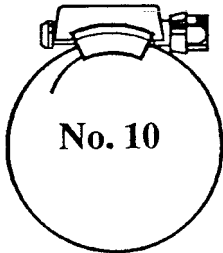

Part No.	Description	Fits Tubing Sizes	Replaces Compression Clamp P/N
358757	Clamp, Size #10 all stainless steel 5/16 hex head screw	3/4", 7/8" and 1"	380421

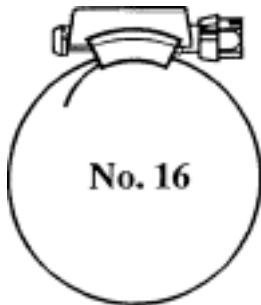

Part No.	Description	Fits Tubing Sizes	Replaces Compression Clamp P/N
358758	Clamp, Size #16 all stainless steel 5/16 hex head screw	1", 1 1/8" and 1 1/4"	380422

Installation of Tubing Clamps

Select the proper size tubing clamp as listed in the charts to replace the compression clamps in the manual. When installing the clamps, place the clamp near the tube end with the top of the clamp over the slot in the tube as shown in the illustration.

After adjustment of the tubing lengths, tighten the clamp with a 5/16 inch nut driver or open end wrench until the tubing will not twist or telescope.