

308 Industrial Park Road  
 Starkville, MS 39759 USA  
 Ph: (662) 323-9538 FAX: (662) 323-6551

## Model AV-18VS 10-80 Meter Vertical Antenna

# INSTRUCTION MANUAL

### General Description

The Hy-Gain Model 18V-S is a trapless, vertical antenna which is manually tuned to any band, 10 through 80 meters, by a simple adjustment of the feed point on the base inductor. It is designed to be fed with 50 ohm coax, and works efficiently for DX or local contacts. It now features stainless steel hardware for all electrical and most mechanical connections.

The antenna is self-supporting and can survive winds in excess of 80 mph. It is highly portable and knocks down to an overall length of 5 feet.

### WARNING

When Installing your system, take extreme care to avoid any accidental contact with power lines or *overhead* obstructions. Failure to exercise this care could result in serious or fatal injury.

### Feedline

Use 50 ohm coaxial cable (RG-213/u preferably) and attach to the antenna as shown in Figures 2, 5 and 7. After attaching the coax, seal it from moisture using Coax-Seal<sup>®</sup> or some similar substance.

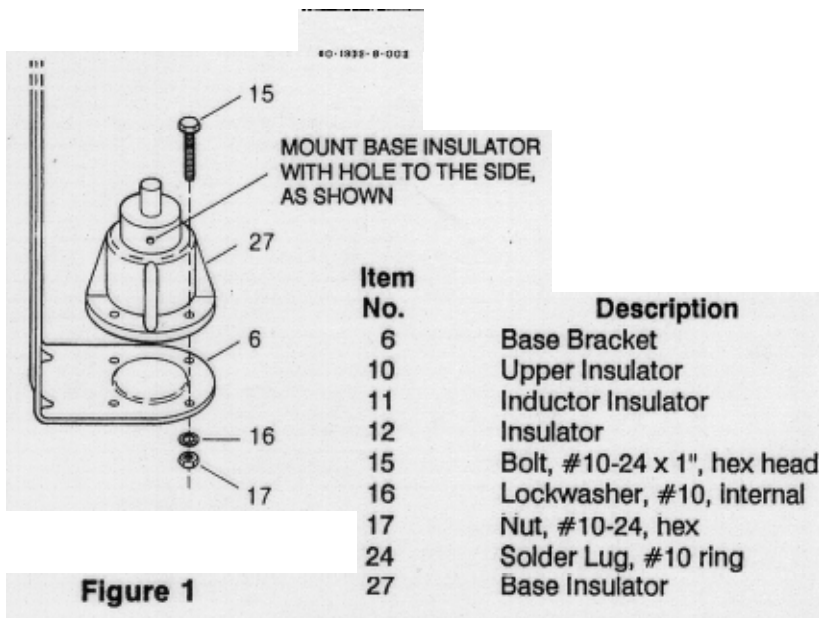

Figure 1

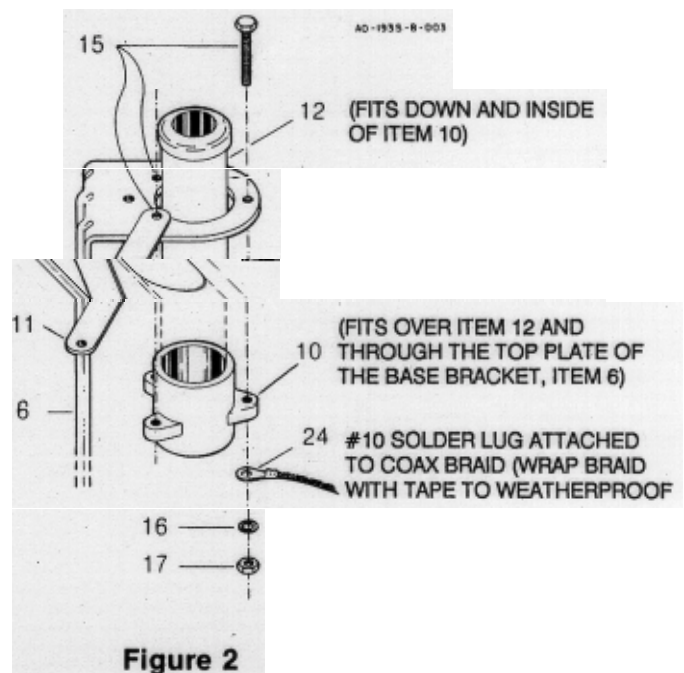

Figure 2

## Assembly

Select the base bracket and the lower base insulator and install as shown in Figure 1.

Select the two upper base insulators and the base inductor insulator strap and install as shown in Figure 2.

NOTE: Coax braid must also be installed as shown.

Item#	Description
1	Tube, aluminum, M1, 1 1/4" x 9"
2	Tube, aluminum, M2, 7/8" x 53 1/2"
3	Tube, aluminum, M3, 3/4" x 53 1/2"
4	Tube, aluminum, M4, 5/8" x 53 1/4"
5	Tube, aluminum, M5, 7/16" x 54"
9	Caplug, 7/16", black
13	(not used)
14	Screw, #10-24 x 3/8", hex head
28	#4 Hose clamp
29	#6 Hose clamp
30	#10 Hose clamp

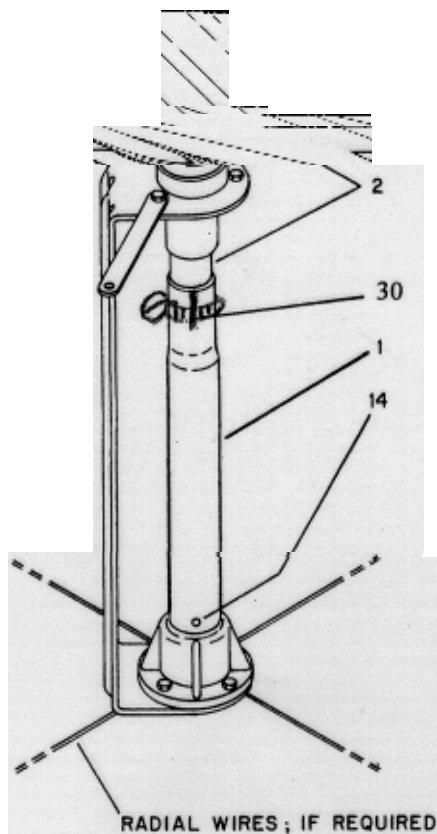

Section M2 has a hole drilled through both walls, near each end. the end with the hole 1 1/2" from the end fits inside section M1.

RADIAL WIRES ; IF REQUIRED

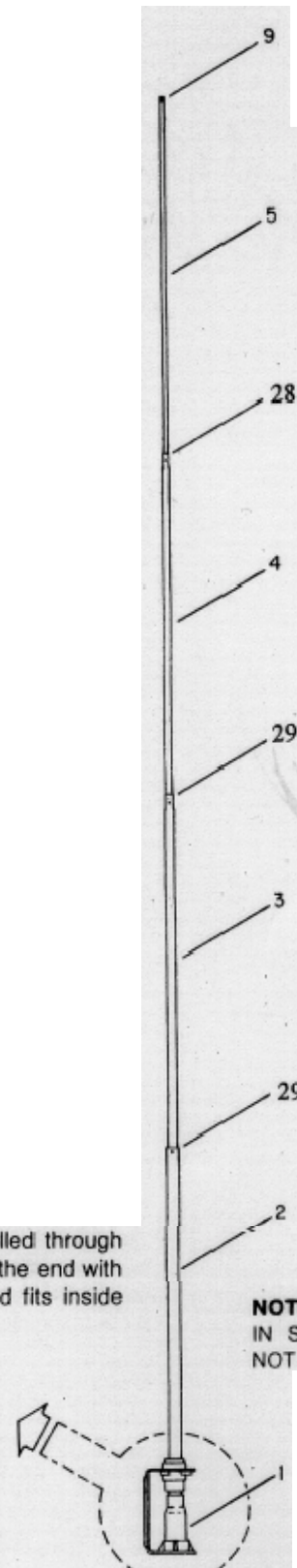

NOTE: THIS ILLUSTRATION IS IN SCALE IN LENGTH ONLY; NOT IN WIDTH.

Figure 3

Select the M1 section of tubing (1<sup>1/4</sup>" ) and place it over the top of the lower base insulator. Align the hole in the base of the M1 section of tubing with the hole in the lower base insulator as shown in Figure 3. Place a #10 (Item 14) screw in the hole and tighten securely.

Select the M2 section (7/8" x 53 1/2") and slip the small hole end through the two upper insulators (see Figure 2) into the M1 section. Fasten with #10 hose clamp (Item 30) as shown in Figure 3.

AO-193S-C-005

Item No.	Description
7	Inductor Coil
8	Clamp, 7/8"
18	Bolt, 1/4" -20 x 1", hex head
19	Lockwasher, 1/4", internal
20	Nut, 1/4"-20, hex
21	U-Bolt, 5/16" x 1 5/8" x 2 1/4"
22	Lockwasher, 5/16", split
23	Nut, 5/16"-18, hex
26	Inductor Clip Assembly

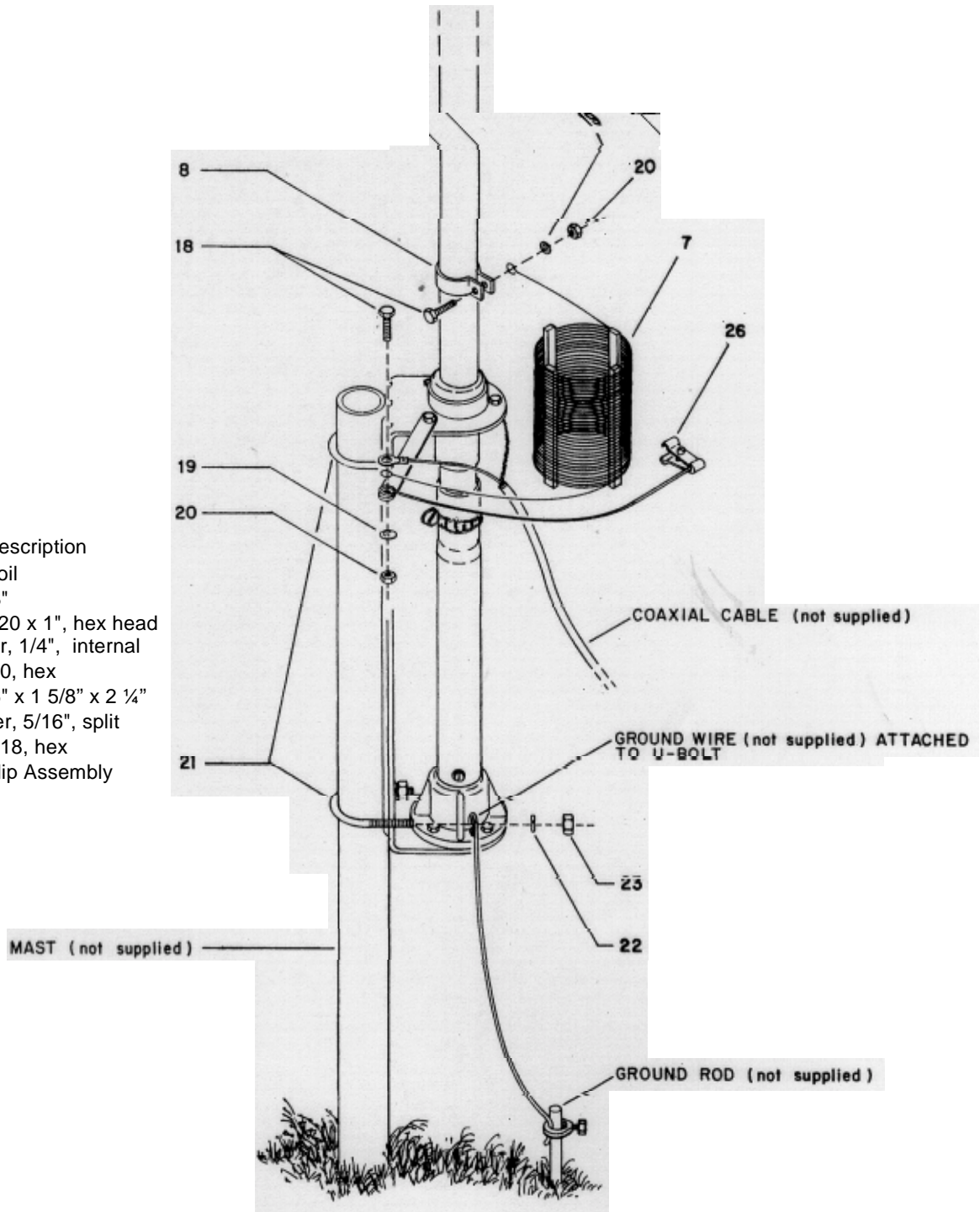

Figure 3

Select the M3 section ( $\frac{3}{8}$ " x 53'h") and slip the end with the smallest hole into the **M2 section and fasten with #6 hose clamp (item 29).**

Select the M4 section ( $\frac{5}{8}$ " x 53 $\frac{1}{4}$ ") and slip the end with the smallest hole into **M3 section and fasten with #6 hose clamp (item 29).**

Select the M5 section ( $\frac{7}{16}$ " x 54") **and slip the slotted end into M4 section.**

Place a  $\frac{7}{16}$ " caplug on the end of the antenna.

Now select the base inductor coil, the tuning clip and the short length of wire. Install as shown in Figure 4.

NOTE: Coax center conductor must also be connected as shown in Figure 4.

Attach the top lead of the base inductor coil to the M2 section (just above the M1 section) as shown in Figure 4.

## Operation

Attach the coax to your transmitter. Attach the tuning clip to the base inductor and tighten it securely. The chart shows an approximate setting. When counting the turns, count from the top-of-the coil. The unused turns below the clip are automatically shorted out to allow you to operate the antenna at full, legal power output without overheating the base inductor with RF energy.

The chart on this page should be reasonably close, but due to different mounting locations, different soil conductivity, and other variations in your individual installation, the exact match is best determined by using an SWR bridge with your transmitter and tapping for lowest SWR. The figures shown in the chart are for ground mounting only. Due to the variations in the length of the ground wire, it is impossible to provide a chart for elevated mounting.

NOTE: Count all turns indicated below as complete turns of the coil from the top.

NONE indicates attachment of tuning clip above turns of coil.

Setting	10 Meter	15 Meter	20 Meter	30 Meter	40 Meter	80 Meter
PHONE	2 $\frac{1}{2}$	NONE	NONE	NONE	8 $\frac{5}{8}$	22 $\frac{1}{2}$
CW	3	NONE	NONE	5 $\frac{1}{2}$	9	25 $\frac{1}{2}$

NOTE: Connect tuning clip right at clamp connection on the M2 section when number of turns indicated is NONE.

## Ground Mounting

Drive a 3 foot piece of pipe (such as 1 1/4" plumbers pipe) into the ground and attach the antenna as shown in Figure 4. Drive an 8 foot copper-clad steel ground rod into the ground. Attach the ground rod to the base using #10 wire. Remember, a vertical antenna is only as good as the ground system it is working over. The better the ground system, the better your antenna will work. If difficulty is experienced, try adding 2 or 3 more ground rods about the antenna base and attach each with a separate wire. Radials may be attached to the ground rods for increased efficiency.

## Elevated Mounting

The Model 18V-S can be mounted alongside the house on a short mast or on top of the roof using a short mast section. *When* mounting more than 24" above the ground, you must use a radial system similar to that shown in Figure 5. This radial system should then be grounded to an earth ground by the shortest path possible. *Do not change the mounting point of the base inductor. Mount it only as shown in this manual.*

### CAUTION

*Make* certain none of the radial wires touch the inductor coil or damage

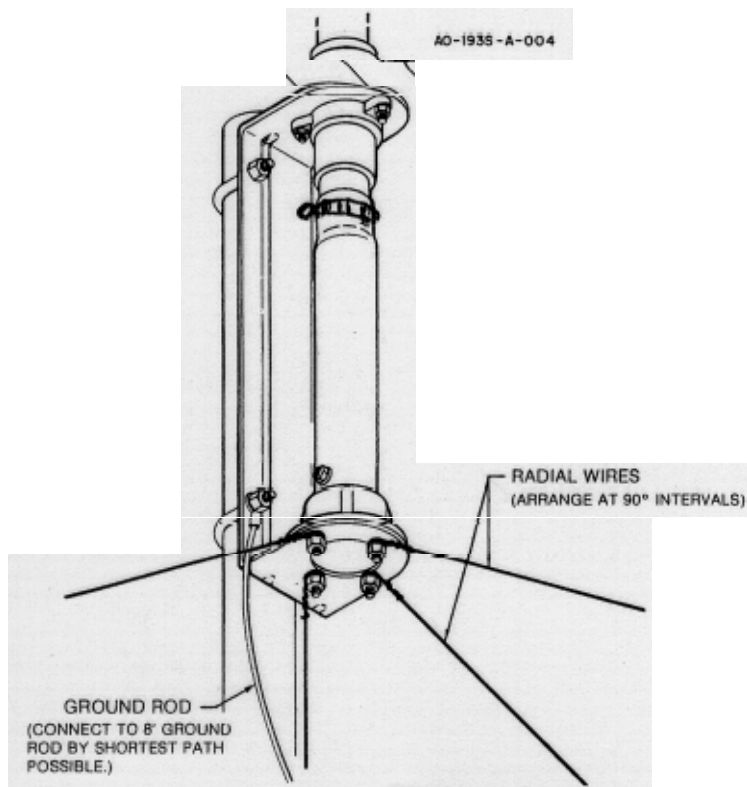

Figure 5 Method of Attaching Radial Wires to Base

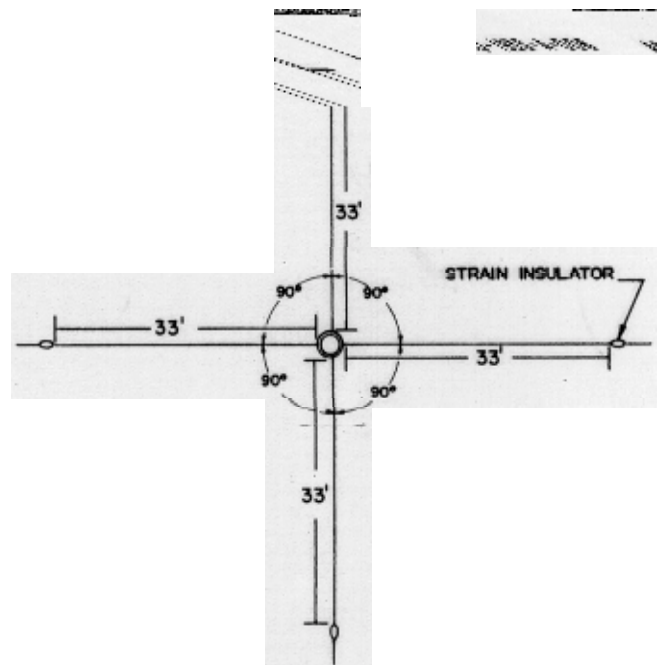

Figure 6 Minimum Radial Configuration

## Radials

The radials can be constructed of either copper or aluminum wire. The recommended method of installing the radials is to attach them to the screws at the bottom of the base assembly. The 33 foot dimension is measured from the base assembly to the strain insulator, and is optimum for 40 meter operation only. You may wish to add shorter or longer radials for other bands that you plan to operate on.

### WARNING

***The antenna and radials are "hot with RF" proportional to the operating power. Be sure to keep out of the reach of small children and pets.***

### PARTS LIST

Item#	Part#	Description	
1	177963	Tube, aluminum, M1, 1 1/4" x 9".....	1
2	173276	Tube, aluminum, M2, 7/8" x 53 1/2" . . . . .	1
3	173274	Tube, aluminum, M3, 3/4" x 53 1/2".....	1
4	173273	Tube, aluminum, M4, 5/8" x 53 1/4" . . . . .	1
5	173272	Tube, aluminum, M5, 7/16" x 54".....	1
6	160043	Bracket, base .....	1
7	723267	Coil, inductor .....	1
	872000	Parts Pack 18V-S, Stainless Steel .....	1
8	169339	Clamp, 7/8".....	1
9	455644	Caplug, 7/16" (black) .....	1
10	463056	Insulator, upper .....	1
13		(Not Used)	
12	478002	Insulator .....	1
13	515852	Screw, #8 x 1/2", pan head, Type A, slotted .....	2
14	526472	Screw, #10-24 x 3/8", hex head, slotted .....	1
15	504069	Bolt, #10-24 x 3/8", hex head .....	7
16	565697	Lockwasher, #10, internal .....	7
17	554071	Nut, #10-24, hex.....	9
18	502958	Bolt, 1/4" -20 x 1", hex head .....	2
19	562961	Lockwasher, 1/4", internal .....	2
20	554099	Nut, 1/4" -20 hex .....	2
21	543792	U-bolt, 5/16" x 1 5/8" x 2/4.....	2
22	564792	Lockwasher, 8/16", split .....	4
23	555747	Nut, 5/16" -18, hex .....	4
24	678922	Solder lug, #10 ring .....	1
25		(Not Used)	
26	872817	Inductor clip assembly.....	1
27	877961	Insulator base.....	1
28	745-31048	#4 Hose Clamp (358759) .....	1
29	745-31065	#6 Hose clamp (358756) .....	2
30	745-31105	#10 Hose Clamp (358757) .....	1



# ADDENDUM

## ENGINEERING REPORT

### PHASED MULTI-BAND VERTICALS for ADDITIONAL GAIN and LOW ANGLE RADIATION

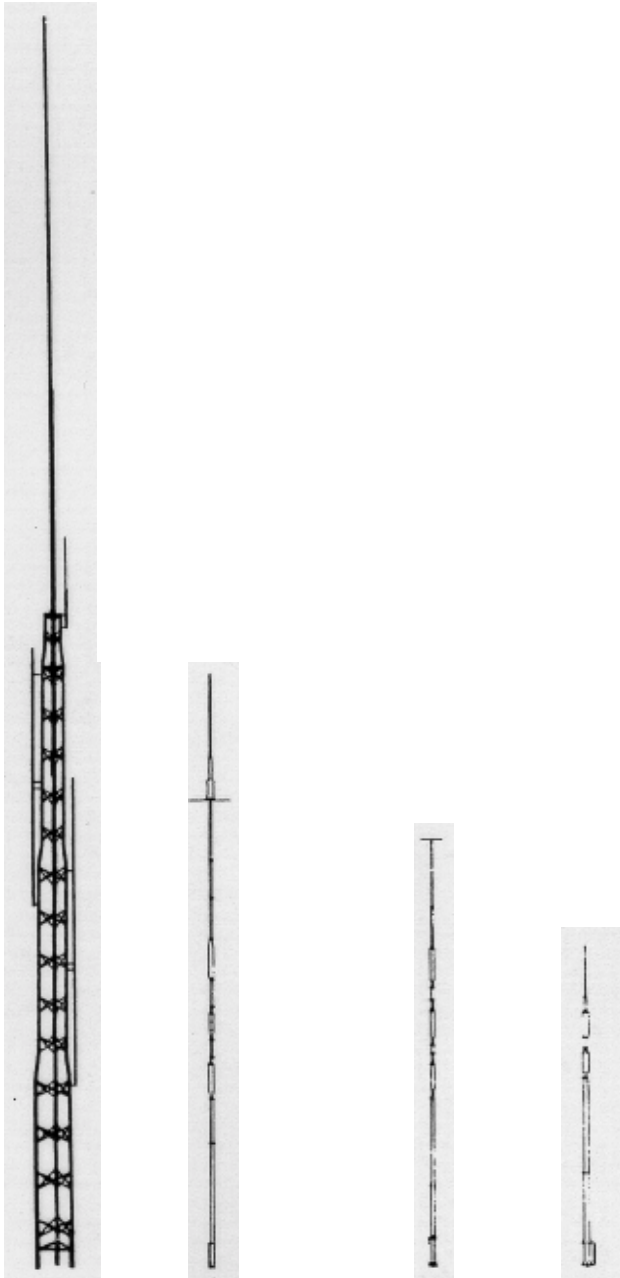

AV-18HT AV-18VS/18AVT AV-14AVQ AV-12AVQ

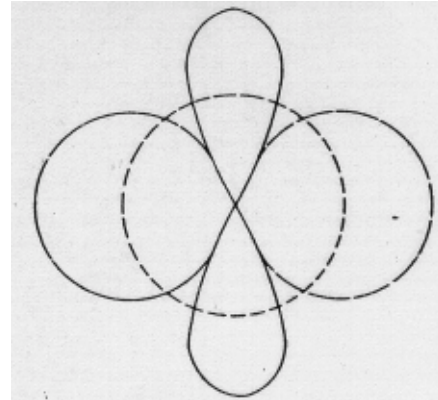

Phased Patterns

### *INTRODUCTION*

The following Hy-Gain verticals are well adapted for the phasing arrangements shown in this report.

#### MODEL 18HT-S HY-TOWER

The 18HT-S is a multi-band vertical antenna with automatic band selection of 10-80 meters by means of a unique stub decoupling system. The Hy-Tower with a base loading coil operates efficiently on 160 meters. The system is foolproof, fed directly with a single 50 ohm coax. No guys are required for the 24 feet high, self-supporting tower. The top mast extends the height to 50 feet. Two units make an ideal phased array.

#### MODEL 18AVT/WB-S VERTICAL

The 18AVT/WB-S is a multi-band trap vertical for 10 through 80 meters. It is completely factory pre-tuned and exhibits an extremely low angle DX radiation pattern. It is easy to assemble, light weight which one man can install. A single 50 ohm coaxial feedline is required. Two or three 18AVT/WB-S's make an excellent phased array.

## MODEL 14AVQ/WB-S

The 14AVQ/WB-S is a self supporting multi-band trap vertical for 10 through 40 meters and is completely factory pre-tuned. It is the world's most popular ham antenna with an overall height of 19 feet. The antenna is thoroughly weatherproofed and has a low angle DX radiation pattern. It may be ground mounted or installed on "Roof Top" with a radial system.

## MODEL 12AVQ

The 12AVQ is a self supporting 13 1/2 foot multi-band trap vertical for 10, 15 and 20 meters. Completely factory pre-tuned with SWR of 2:1 or less with a low angle DX radiation pattern. The antenna has a new fiberglass impregnated styron base insulator. It may be ground mounted with earth acting as the "image antenna" or installed on the roof using a radial system.

## DESCRIPTION

Increased activity on 80 and 40 meters has created a need for an antenna with power gain and directivity. Doublet and long wire antennas are no longer effective due to increased QRM. At these low frequencies, the radiation system must be lengthy and height above ground is extremely important to obtain the "low" angle of radiation needed for DX.

## Part 1 - SINGLE BAND

### BI-DIRECTIONAL ARRAY (Four Quadrants)

#### THEORY' OF OPERATION

Two identical vertical antennas can be installed as a phased array. When excited by RF energy, gain is achieved by control of the directional pattern. This direction pattern control results in added gain by sharpening lobe patterns and concentrating the radiated energy at very low angles. Signal flutter is reduced and reception is vastly improved.

Beams are excellent, but require a large supporting tower and "hefty" rotating system. Inverted V dipoles and slopers require a large tower and plenty of property.

The vertical "phased array", the answer for "DX" on these frequencies combine gain, directivity and low angle radiation, the three most important DX factors in a communication installation. The vertical is well known for its low angle characteristics. When you combine two identical verticals, properly spaced and phased, the resultant is a concentrated low angle of energy and a power gain. These antennas can be so arranged to give a definite effect on either one or two favorite bands or all band coverage with some pattern compromise and slight loss of gain.

The following data was experimentally derived on the Telex/Hy-Gain test range. Due to the many factors that vary and influence the performance of an antenna, such as grounding and close proximity of surrounding objects, etc., Telex/Hy-Gain cannot guarantee an installation to perform or exhibit the same characteristics as outlined in this report. However, many Amateurs are now successfully using these arrangements. Commercial broadcast stations have been using a similar phasing arrangement for years.

Phased arrays will reduce installation height requirements and still maintain low angle radiation.

Most effective spacing for a bi-directional array is 1/2 wave length. When two verticals are excited in phase the radiation is broadside to the plane of the verticals, offering substantial gain and bi-directional characteristics. Side nulls offer excellent signal cancellation to the undesired direction.



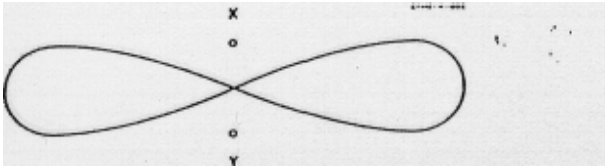

"BROADSIDE" GAIN 3.86

When excited "out of phase" these same verticals can be made to give an "end fire" or bi-directional pattern in the opposite direction through the plane of the verticals. This then nulls out signals in the opposite directions. More gain is exhibited by the broadside pattern over the "end fire" arrangement, but the "end fire" arrangement offers a wider frontal pattern.

Both arrangements offer an excellent advantage over a single vertical since either phasing combination exhibits noticeable signal gain with side attenuation of undesired signals. This added gain and low angle vertical directivity is the advantage of the phased array.

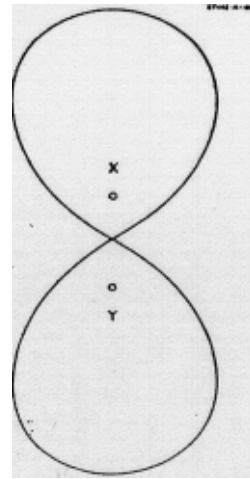

"ENDFIRE" GAIN 23 dB

Phased verticals may be spaced either one quarter wave or one half wave depending upon gain and directional characteristics. The nulls of the phased array are extremely sharp and very pronounced. Typical arrangements of phased arrays and their electrical specifications are illustrated below.

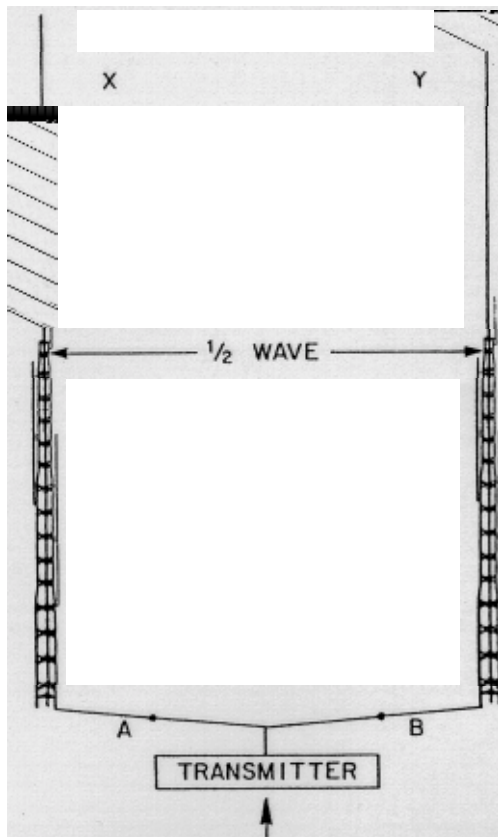

When feedline "A" is the same length as feedline "B" the currents arrive at the base of each antenna at the same time, giving the "inphase" broadside pattern.

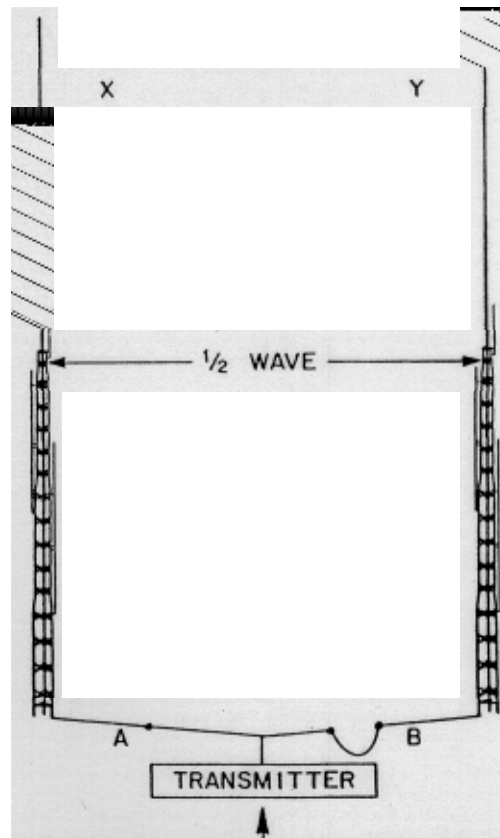

When feedline "A" is 1/2" wave length shorter than feedline "B" the current arrives at antenna "X" 1/2 wave length sooner (180 degrees) than at antenna "Y" giving the "out of phase" end fire pattern.

Figure 1

<b>ELECTRICAL SPECIFICATIONS</b>		
	<b>Broadside</b>	<b>End Fire</b>
Pattern Width, half power points	60 degrees	80 degrees
Gain over single vertical	3.86 dB	2.3 dB
Side Attenuation	30 dB	20 dB
Impedance	50 Ohms	50 Ohms
Directional Characteristics	Bi-Directional	Bi-Directional

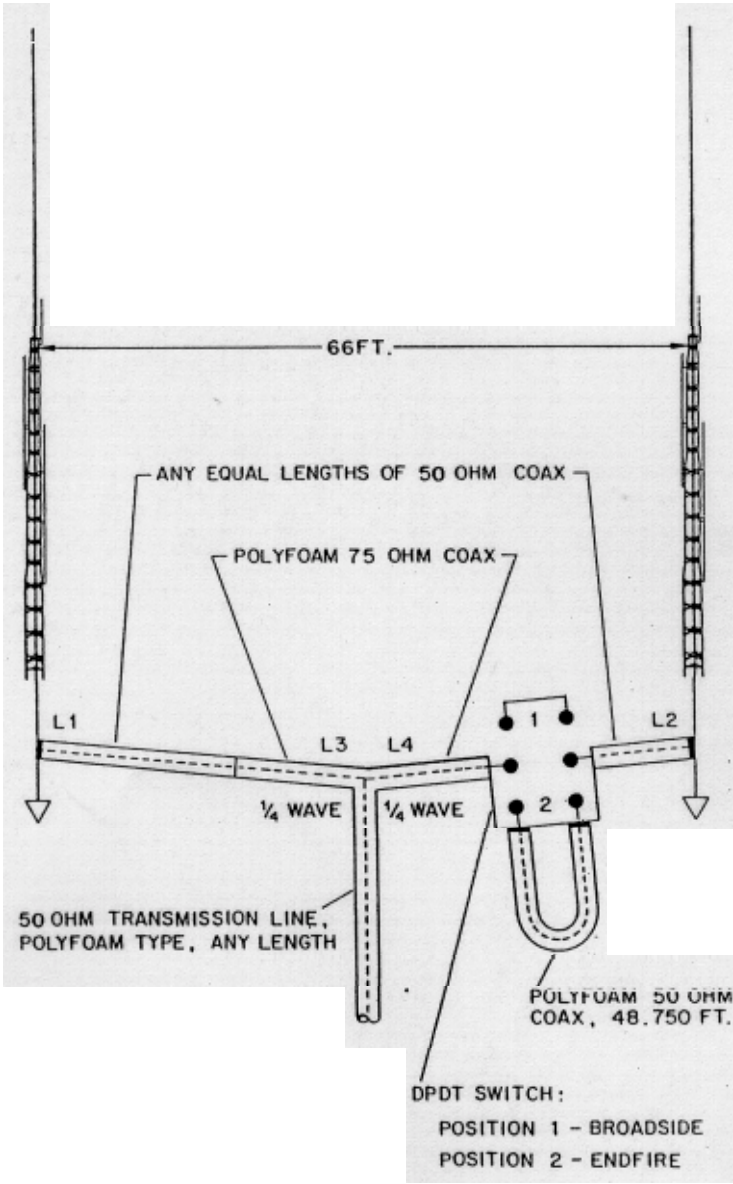
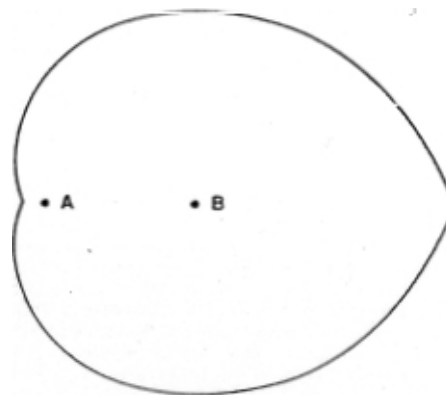

Figure 2. Typical Installation Phased (2) 18 HT  
 40 Meters 7200 KHz Design Frequency

# CARDIOID ARRAY (Uni-directional)

When two or **three identical verticals** are excited **directly and** fed 90 degrees out of phase with a spacing of  $1/4$  wave length, a cardioid pattern results. This pattern may be switched in either direction. By inserting a  $1/4$  wave length delay line the antenna will "fire" or be directive to that particular element.



TWO VERTICALS

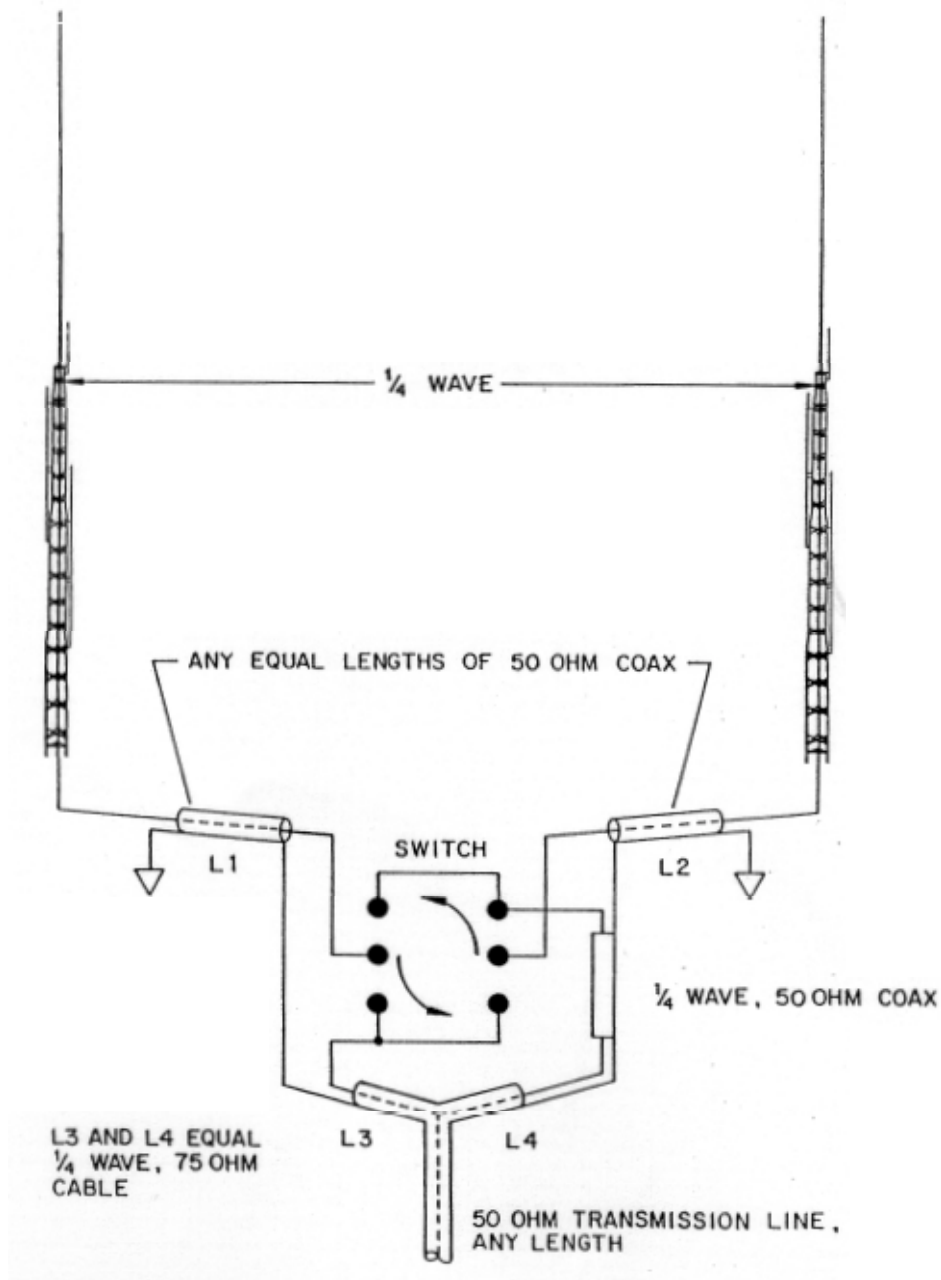
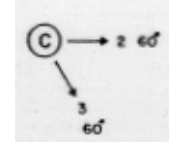
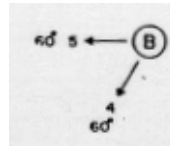
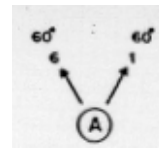

Figure 3 Cardioid-Unidirectional With Two *Selectable Directions*

The beam pattern for two 1/4 wave length verticals will be approximately 120 degrees. An arrangement of three switchable verticals gives a 60 degree pattern in six selectable directions.



TOP VIEW - 3 VERTICALS

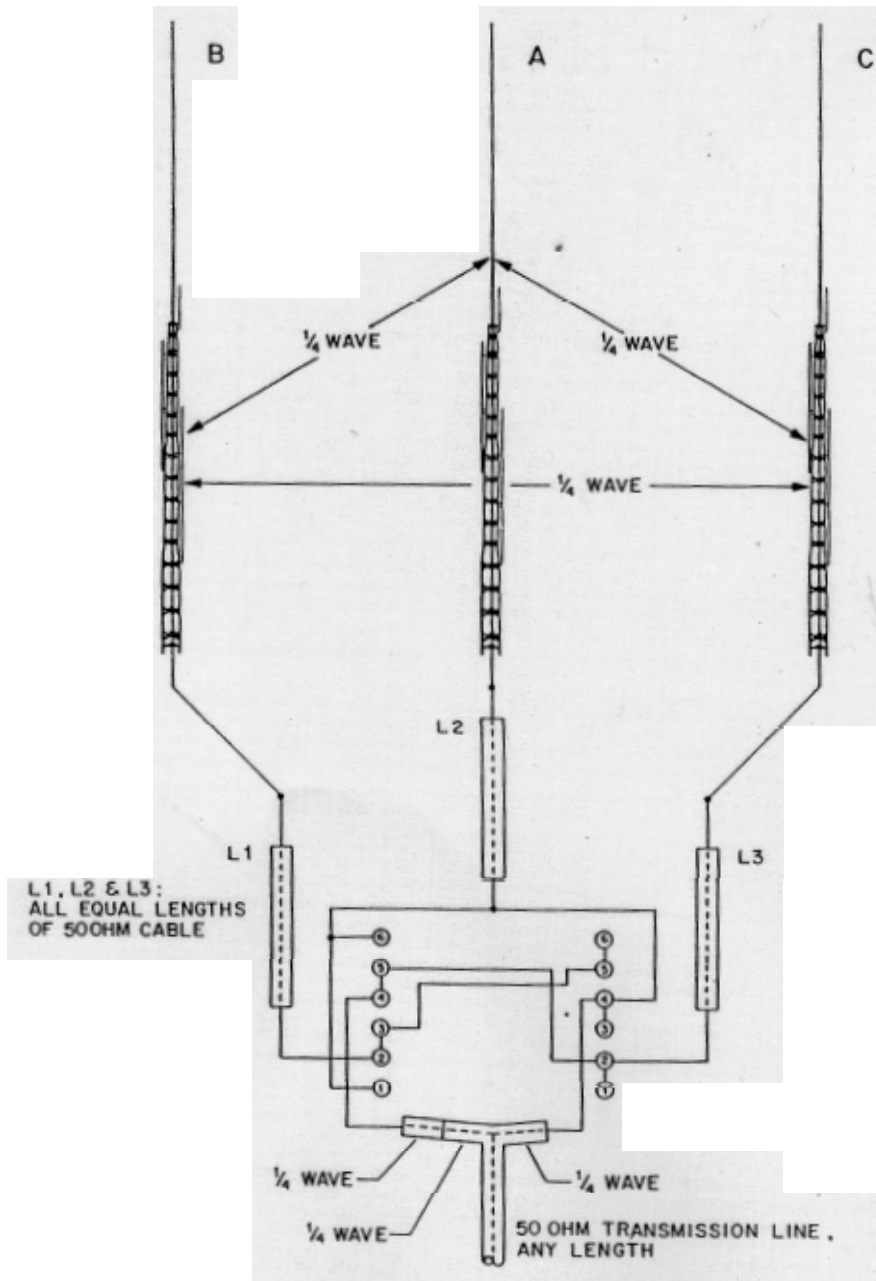

Figure 4  
360 Cardioid Arrangement

## ELECTRICAL SPECIFICATIONS:

	Two Phased Verticals	Three Phased Verticals
Pattern Width, half power points	120 degrees	60 degrees
Gain over single vertical	4.5 dB	4.5 dB
Side attenuation	20 dB	20 dB
Rear attenuation	30 dB	30 dB
Impedance	50 Ohms	50 Ohms
Directional Characteristics	Uni-directional	Uni-directional

VSWR: Exceptionally low SWR is present with a phased array. If phasing lines are correctly measured and the terminal impedance of each antenna is very close to 50 Ohms: Typical SWR: Broadside 1.2:1, Endfire 1.4:1, Cardioid 1.2:1.

### P H A S I N G   L I N E S :

The 1/4 and 1/2 wave transformers, identified as L3, L4 and L5 are calculated from the following formula:

$$\frac{1}{4} \text{ wave} = \frac{246000 \times \text{vel. factor} - \text{reg. coax.}}{\text{frequency (in KHz)}} \times 0.66$$

EXAMPLE:

$$\begin{aligned} \frac{1}{4} \text{ wave at } 7200 \text{ KHz} &= \frac{246000}{7200} = 34.16 \\ &\quad \times .75 \\ &= 25.62 \text{ ft.} \end{aligned}$$

## PART 2 - MULTI-BAND OPERATION

### M U L T I - B A N D I N G

Multi-banding is easily accomplished by choice spacing two identical verticals. (refer to charts A,B, and C and associated Figures 1 through 5) Switchable 1/4 wave length and 1/2 wave length phasing cables must be employed for each band. These cables can be placed in the station in any suitable fashion along with a manual switching arrangement or relay system.

### *RADIATION PATTERN:*

Consideration must be given to the fact that 1/2 wave spacing (optional) is ideal for phasing. When multi-banding with close and wide spacing, compromise radiation patterns must be expected. In most cases a choice spacing serves 3 bands most effectively with good directional characteristics, added gain and low angle performance.

## OPTIONAL SPACING

Various antenna spacings may be selected from charts A, B, and C, for single band, duo band or multi-band arrangements. Associated radiation patterns for a specific spacing is shown in Figures 1 through 5 for each band.

If the  $3/4$  wave length patterns are not desirable, a single vertical only can be switched in use to obtain an omni-directional pattern.

## INSTALLATION

The vertical antenna requires a minimum amount of space. Ground mounted or elevated arrays are easily installed.

Antenna placement and orientation is a most important factor when planning maximum effectiveness in desired directions. Each vertical should be installed in the clear relatively free of surrounding objects in order to maintain its design 50 Ohm terminal impedance.

Each antenna must be mounted at the same height on or above ground and be so arranged according to their radiation pattern to offer desired directivity.

The phased array is primarily designed for long range and DX communications. In cases where close and medium distance contacts are hampered by the array's low angle characteristics and a higher angle is required, switching arrangements can select one vertical for this coverage.

## SWITCHES & CONNECTORS

Low loss constant impedance type coaxial switches and connectors should be used when splicing phasing lines. B&W multi-position, single or multi-gang coaxial switches with Amphenol coaxial cable and "T" connectors are recommended.

## FIELD TESTS

Actual field tests comparing one vertical to the phased array results in doubling the receiver sensitivity and offering up to 12 dB of signal increase. An attenuation of up to 30 dB is noticeable on the phased verticals with half wave spacing. With quarter wave spacing, up to 20 dB cardioid, and 30 dB front-to-back attenuation can be obtained.

"End Fire" directivity offers a larger area of radiation at slightly reduced gain as compared to the broadside arrangement. The "broadside" arrangement is recommended for communications at greater distances whereas the "endfire" arrangement would be so arranged to cover a larger area of communications. Special attention to the coax phasing line lengths and their proper placement is of utmost importance.



- A. 80 meter bi-directional pattern (all SW positions 3) refer to Figure 1, Part 2 "Radiation Patterns"

NOTE: Due to close electrical spacing (1/4 wave) on 80 meters for Broadside (position 1) and Endfire (position 2) the SWR may be somewhat higher than 1/2 wave spacing. SW3 selects

- B. 40 meters all switches in position 1 selects Bi-Directional patterns. Use SW2 for broadside (position 1) Endfire (position 2).

- C. All switches in position 2 selects cardioid pattern. SW4 selects direction of cardioid pattern.

NOTE: All connecting lines are exaggerated in length. These lines must be direct and short as with any coax hook-up practice.

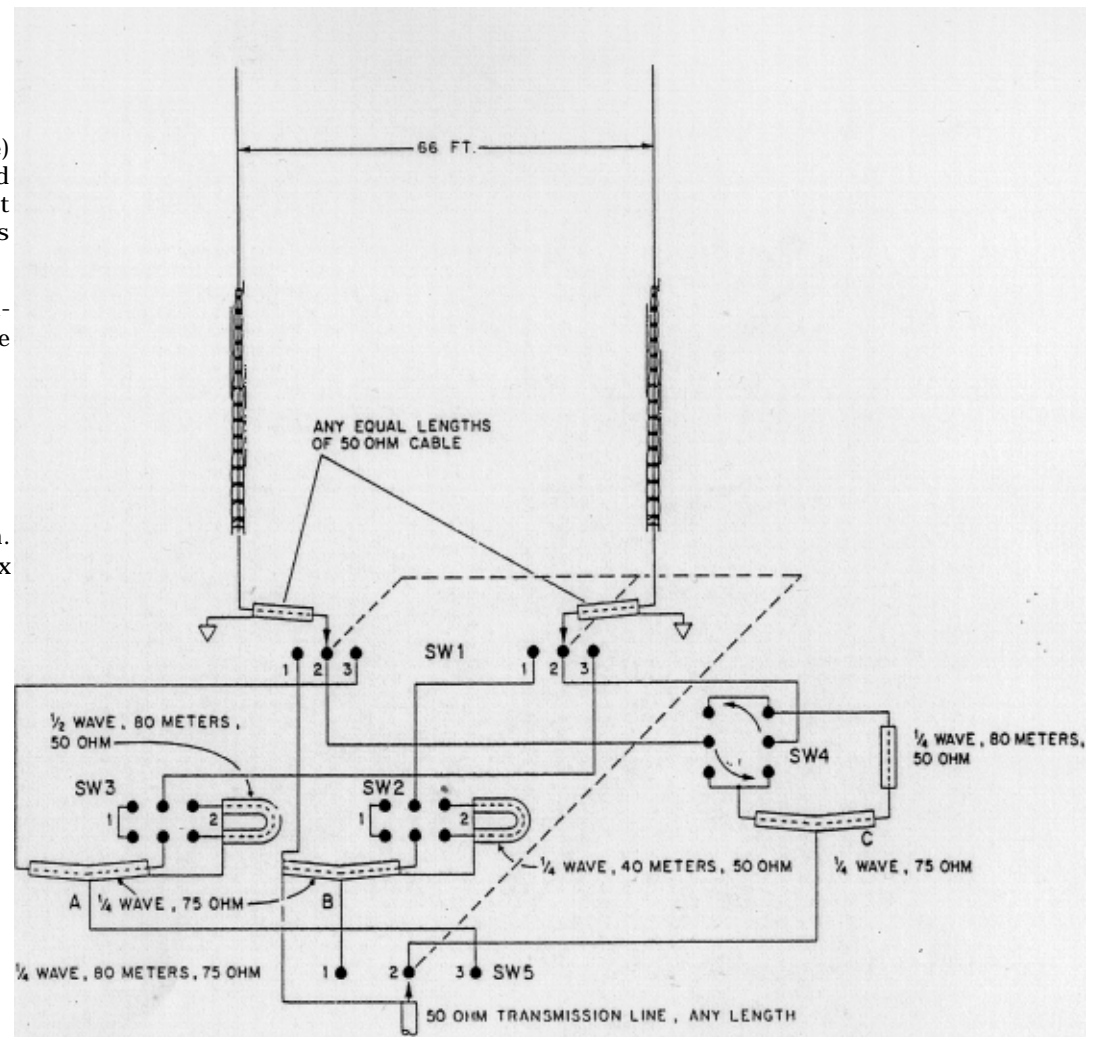
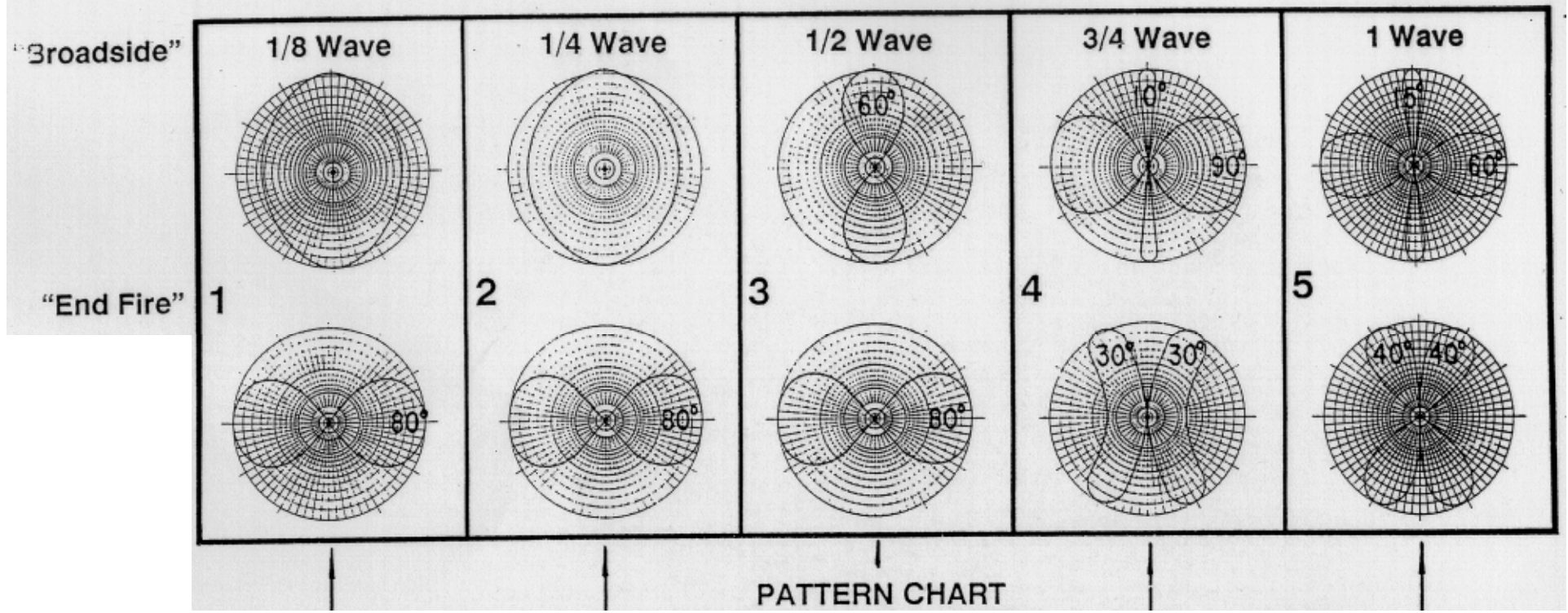

Figure 5 Typical installation (2) 18HT-S Phased for 80 and 40 Meters Selectable Broadside and Endfire Patters on 40 Meters Selectable Broadside and Endfire Patterns on 80 Meters Selectable 2 Directions Cardioid on 80 Meters



PATTERN CHART

Spacing	Single Band Arrangement				
125'			80		
66'			40		
33'			20		
Dual Band Arrangement					
66'		80	40		
33'		40	20		
16'		15	10		
Multi-band Arrangement					
33'	80	40	20	15	10
66'		80	40	20	

Note: Corralate Patterns to spacing used in installation

Figure 6 Radiation Patterns . Typical Spacing For Broadside And Endfire Arrangements

## **hy-gain**® LIMITED WARRANTY

**Hy-Gain** Warrants to the original owner of this product, if manufactured by **Hy-Gain** and purchased from an authorized dealer or directly from **Hy-Gain** to be free from defects in material and workmanship for a period of 12 months for rotator products and 24 months for antenna products from date of purchase provided the following terms of this warranty are satisfied.

1. The purchaser must retain the dated proof-of-purchase (bill of sale, canceled check, credit card or money order receipt, etc.) describing the product to establish the validity of the warranty claim and submit the original or machine reproduction of such proof of-purchase to **Hy-Gain** at the time of warranty service. **Hy-Gain** shall have the discretion to deny warranty without dated proof-of-purchase. Any evidence of alteration, erasure, or forgery shall be cause to void any and all warranty terms immediately.
2. **Hy-Gain** agrees to repair or replace at **Hy-Gain's** option without charge to the original owner any defective product under warranty, provided the product is returned postage prepaid to **Hy-Gain** with a personal check, cashiers check, or money order for \$8.00 covering postage and handling.
3. Under no circumstances is **Hy-Gain** liable for consequential damages to person or property by the use of any **Hy-Gain** products.
4. Out-of-warranty Service: **Hy-Gain** will repair any out-of-warranty product provided the unit is shipped prepaid. All repaired units will be shipped COD to the owner. Repair charges will be added to the COD fee unless other arrangements are made.
5. This warranty is given in lieu of any other warranty expressed or implied.
6. **Hy-Gain** reserves the right to make changes or improvements in design or manufacture without incurring any obligation to install such changes upon any of the products previously manufactured.
7. All **Hy-Gain** products to be serviced in-warranty or out-of-warranty should be addressed to **hy-gain, 308 Industrial Park Road, Mississippi 39759, USA** and must be accompanied by a letter describing the problem in detail along with a copy of your dated proof-of-purchase.
8. This warranty gives you specific rights, and you may also have other rights which vary from state to state.