

YRC-1 Digital Antenna
Rotator Controller
For
Yaesu Rotators

Model YRC-1 Instruction Manual

hy-gain[®]

308 Industrial Park Road
Starkville, MS 39759 USA

Table of Contents

Precautions.....	3
YRC-1 Digital Antenna Rotator Controller.....	4
YRC-1 Digital Control Unit Specifications:	4
Installation.....	5
General Rotator Precautions.....	5
Wiring and Check-Out.....	5
CAUTION:.....	6
NOTE:	6
Operation of YRC-1 Controller	8
Menu Functions	8
Menu Items.....	8
Menu Details	9
Manual Operation	10
MANUAL ROTATION.....	10
HEADING SET.....	10
Computer Operation	10
Software Control	10
OPERATIONAL NOTES	11
USB COMMAND SET.....	11
Schematic Diagram.....	12
Block Diagram.....	14
How to Get Factory Service.....	15
12-MONTH LIMITED WARRANTY.....	15

Yaesu is a registered trademark of Yaesu Musen Co., LTD. This product is not manufactured or serviced by Yaesu.

Precautions

Towers and antennas require caution during erection and placement! Extreme care must be taken during erection so that metal tower and antenna parts DO NOT contact power lines, even if the parts slip, rotate, retract, fall or fracture!

Antenna position mechanisms (towers and rotators) must be placed so that if they fail, the parts of the antenna system cannot contact power lines, be a hazard to individuals, or endanger property.

The YRC-1 Control Unit is not weatherproof and must be located in a house or other protected location. Connect a ground wire to the terminal on the back of the YRC-1.

Metal towers must be grounded properly at the tower location before the tower is erected. This is to minimize electrical hazard and reduces the possibility of lightning damage. DO NOT bury bare aluminum wires or stakes in the ground. Use copper or copper-clad ground stakes. The service entrance ground should be checked. The household electrical outlet should be the 3-prong type (grounded back to the service entrance). Follow all local building codes and the NFPA National Electric Codes for grounding.

The YRC-1 has been carefully designed and manufactured to give many years of trouble-free service when carefully and professionally installed. It consists of the strongest and best commercially available components. This product is manufactured in the U.S.A.

YRC-1 Digital Antenna Rotator Controller

The YRC-1 digital control unit features a Large LCD display indicating the beam heading, manual and computer controlled beam heading selection, and manual rotation controls. Settings in memory include brake delay, rotator coast control, North and South center headings, adjustable sleep time, and call sign display.

The YRC-1 is designed as a replacement controller for both AC and DC rotators and will work with the following Rotators:

- G-450
- G-650
- G-800/SA/DXA
- G-1000SA/DXA
- G-2800DXA

YRC-1 Digital Control Unit Specifications:

Size	4.125" x 8.5" x 9"	
Weight	6.25 lbs. (2.84 Kg)	
Voltage	120VAC or 240VAC (optional YRC-1X)	
Coast Delay	0-10 seconds	DEFAULT 0
Sleep Delay	1-240 minutes or continuous ON	DEFAULT 20

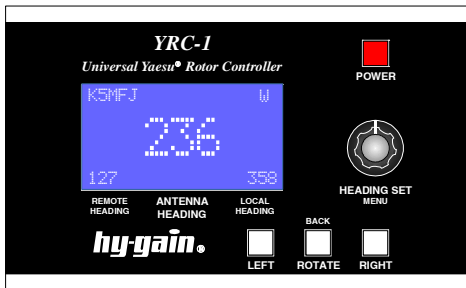

Figure 1. Front Panel

Front Panel Controls

- POWER** Power ON/OFF
- LEFT** Manually rotate left/CCW
- RIGHT** Manually rotate right/CW
- HEADING SET/MENU** Set the locally controlled antenna heading or bearing. Pushing in the "HEADING SET" selects any menu or the menu function selected or executes the menu function.
- ROTATE** Instructs the controller to rotate the antenna to the locally set heading.

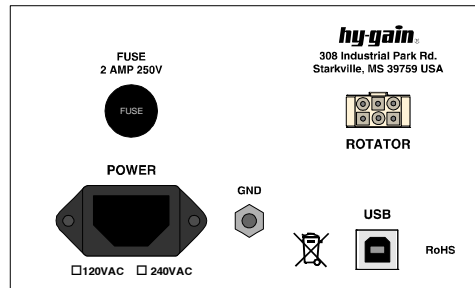

Figure 2. Back Panel

Back Panel Connections

- GROUND** Chassis ground
- FUSE** Protective fuse
- USB** USB COM Port
- ROTATOR OUT** Rotator connections
- POWER** 120 VAC Input (240VAC Input optional)

Installation

The YRC-1 is designed to be a replacement controller for the standard Yaesu controllers and most likely a new install is not being done. Even so when installing or working on the rotator follow the Yaesu instructions for installation of the rotator to insure proper installation and operation.

General Rotator Precautions

1. Unbalanced weight: Weight should be as closely balanced as possible. Unbalanced weight in an antenna creates a bending moment of force which is concentrated on the mast at the point where it is clamped to the rotator.
2. Wind Pressure: Balanced wind pressure against the antenna system produces a bending force on the mast which can cause the same stresses as unbalanced weight. To minimize these forces, a thrust bearing should be used where possible, the antenna should be as close to the top of the tower as possible and the rotator shelf should be as low as possible
3. Unbalanced Wind: If the antenna has unequal wind areas and element spacing on each side of the mast attachment point, it could produce torque on the support mast. This is similar to the principle of a weather vane. If the

unbalance is high enough or the wind velocity is high enough, this could prevent rotation or could damage the limit switches. To minimize this effect, the antenna should be designed for minimum mast torque or "torque compensators" added to produce minimum mast torque.

4. Mast Binding: If the antenna support mast binds within the tower due to ice accumulation or other reasons, this could prevent rotation
5. Extreme Cold: If the ambient temperature is at or below -30 degrees F, this could prevent rotation

The YRC-1 checks for rotator movement upon giving the command to rotate and if no movement is detected within 8 seconds, it will stop trying to rotate. If no movement is detected the display will flash MOTOR above the main heading display.

Some of the older controllers used different connectors that have a different pin order but same numbers. Wire using the diagram below. Newer rotor connectors have 7 pins. Pin 7 is not used.

Wiring and Check-Out

The YRC-1 is designed to be a replacement controller for the standard Yaesu controller. To this point the wiring should be as simple as unplugging from the old controller and plugging into the YRC-1.

The pins of the plastic connector and the rotator connector correspond, that is 1 to 1 and so on. Pin 7 on the metal rotator connector is not used. Refer to the Yaesu manual for more wiring details.

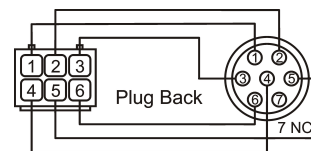

Pinout:

- | | |
|---|-----------------------------|
| 1 | Heading Pot High (not used) |
| 2 | Heading Pot Wiper |
| 3 | Heading Pot GND |
| 4 | Motor DC or AC Left |
| 5 | Motor DC or AC Right |
| 6 | Motor AC Common |

Figure 3. Connector Pinout

CAUTION:

Shorts between terminals or grounded leads may damage the rotator. Check the numbered pins on each connector with an Ohmmeter! Pin 1 is connected to pin 1, etc.

1. With the rotator sitting in the upright position (either on the bench or on the tower) and connected to the control unit by the 6-wire cable, plug the control unit power cord into a receptacle and turn it on.
2. Select the type of rotator you are using in the MODEL setup menu. G-450 and G-650 are **AC** models and most of the others like the G-800/SA/DXA, G-1000S/SA/DXA, and the G-2800DXA are **DC** models.
3. The YRC-1 display should look similar to the display shown in Figure 4. The numeric display in the center indicates the current bearing of your rotator. The numeric display in the lower right corner indicates the target bearing that is manually set. The numeric display in the lower left indicates target bearing that is computer set. The character display in the upper right corner indicates the compass heading in "NESW" format. The alphanumeric display in the upper left corner is where the call sign is displayed if programmed. If the center display reads a steady "999", disconnect your control cable and check the cable wiring with an ohmmeter. The resistance of the position sense pot measured between pin 1 and 3 should be 500 ohms plus the cable resistance. The reading between pins 2 and 3 should be somewhere between 0 and 500 ohms depending on the heading of the rotator. Anything much over 500 plus the resistance of the cable indicates a possible problem. Proceed if the cable checks OK. 999 also indicates that the

cable may not be plugged in or the right stop has not been set.

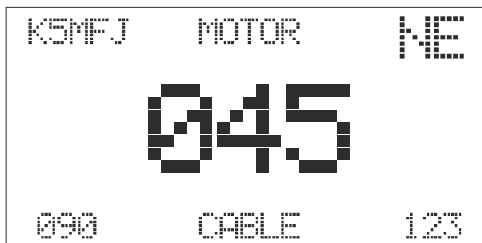

Figure 4. LCD Display

NOTE:

MOTOR is displayed when there is no indication of rotator movement and CABLE indicates a cable problem.

4. Test the rotation by pressing the LEFT or RIGHT buttons and see if the rotator turns in the proper direction. During rotation the display will show the actual heading as it turns. If operation does not work as described, immediately unplug the unit from the AC line and check cable wiring!
5. Calibrate the rotation stops of the YRC-1. Calibration is done with the NORTHSTOP set to SOUTH. Yaesu Rotators will turn more than 360 degrees by about 90 degrees so you will pass 180 degrees when calibrating the right stop and will end up at 270 degrees for the right stop.
 - a. Rotate to the left manually by pressing the LEFT button until the rotator reaches the left mechanical stop then release.

- b. Press and hold the MENU button until the menu is displayed.
 - c. Turn the Heading Set knob if necessary to select "1.CALIBRATE" then press the Heading set knob in to select the function.
 - d. Turn the knob to select "1. LEFT STOP SOUTH" then press the Heading Set knob in to select. You may see the display change to 181 or 182 and the display will say LEFT STOP.
 - e. Next rotate the rotator to the right mechanical stop using the RIGHT button. The display may display the antenna heading of "999" when initially rotated to the right stop. This is OK as long as the left stop did not also display the antenna heading of "999".
 - f. Press and hold the MENU button until the menu is displayed.
 - g. Turn the Heading Set knob if necessary to select "1.CALIBRATE" then press the Heading Set knob in to select the function.
 - h. Turn the knob to select "2. RIGHT STOP SOUTH" then press the Heading Set knob in to select. You may see the display change to 179 or 180 and the display will say RIGHT STOP.
6. After Calibration the current bearing display should show a number between "000" and "359". Test the controls by twisting the HEADING SET knob. The LOCAL HEADING display should change. Using the knob, select a target bearing at least 30 degrees from the current bearing. Push the "ROTATE" button. The rotator should turn to the heading plus or minus 2 or 3 degrees
 7. If this is a new installation, or you are testing the rotator on the bench rotate the system to the center of rotation. You are now ready to install the rotator system in your tower or on your mast. Refer to the instructions in your rotator manual for complete installation information.

Operation of YRC-1 Controller

Menu Functions

Menu Items

1. CALIBRATE
 - a. 1. LEFT STOP SOUTH
 - b. 2. RIGHT STOP SOUTH
2. OFFSET
 - a. Encoder sets the offset from the original setup. Dial in the amount and press the encoder to select the change
 - b. 0 to 360 degrees
3. CALLSIGN
 - a. Turn the encoder to display the character then press the encoder to select and advance to the next character. Press a second time to save the call sign.
4. DEFAULTS
 - a. Resets back to original settings. Select YES or NO to reset.
 - b. All memory settings are retained till it is set back to Default.
5. NORTHSTOP
 - a. Default is NO
 - b. Use the encoder to select YES or NO then press the encoder.
6. SLEEP DELAY
 - a. Default is 10 minutes
 - b. Set 1 to 255 minutes or 0 for always on.
7. COAST SET
 - a. Default 0
 - b. Sets the heading that will turn off the motor before it reaches the heading so it will coast to that heading. 0 to 10 degrees.
8. REVERSE LCD
 - a. Default is NORMAL where the characters are light and the background is blue/dark.
 - b. REVERSE is blue/dark characters and light background.
9. MODEL TYPE
 - a. To select the type of rotator
 - b. Set to either DC or AC
10. CONTRAST
 - a. Set for best contrast. Range is 1 to 32 with a setting around 20 to 25 for normal contrast.
11. EXIT
 - a. To leave menu mode without waiting for it to time out and return to regular operation.

Menu Details

OFFSET is used to compensate for any mechanical errors that may be in the antenna heading. For example: if the antenna is set to 360 degrees and it is found to be actually pointing at 355 degrees, the **OFFSET** can be set to compensate for this error by selecting the value that will show the actual heading.

COAST SET is used to compensate for overshoot of the heading. The inertia of large mass antennas will cause them to pass the desired heading and setting this adjustment will help by turning off the motor and let the antenna coast to the desired spot. This will have to be tried experimentally to find the best setting for your antenna..

CALLSIGN is used to set up the call sign display on the screen if desired. Select the menu function then enter the characters by turning the **Heading Set** knob to the desired character then press the knob in to allow selection of the next character. Once all the characters have been entered press the knob again to exit the mode.

NORTHSTOP Some of the older Yaesu rotators have the mechanical stop at North instead of South. For those rotators you will need to invoke this function. Calibrate the rotator with the YRC-1 set to **SOUTH** stop with the calibration instructions above then set the **NORTHSTOP** to **NORTH** by turning the **Heading Set** knob to select **YES** then press the knob in.

In some cases you may want your antenna centered toward the south with the stops at the north. If this is the case put up the antenna pointed to the **SOUTH** and once installed and ready, select this function and turn the **Heading Set** knob to select **YES** then press the knob in.

SLEEP DELAY is used to put the control into a sleep mode where the LCD back light turns off and the microprocessor goes into a low power state. It will wake back up with the press of any button or any command on the **COM** port. Selecting this menu will allow you to set the time from 0 to 240 in minutes. 0 is always on. When the unit goes to sleep the back light will turn off. Pushing any button, turning the **Heading Set**, or a computer command will wake it up.

REVERSE LCD changes the characters and background from dark blue background and white letters to a white background and dark letters as viewed from straight on. When viewed from a side angle or above the display at the display viewing limits, the characters in normal mode may look dark with a light background. To select the reverse mode select this menu item then turn the **Heading Set** knob to say **YES** for reverse or **NO** for normal then press the knob to select.

MODEL TYPE sets the YRC-1 to control either the DC Rotators like the G-800 and G-1000 or AC like the G-450 Rotators.

CONTRAST adjusts the contrast for best viewing. To adjust select this menu item and turn the heading control for best contrast. The range is 1 to 32 with a setting around 20 as best depending on the display batch received. The contrast setting may or may not be the same setting for best contrast between Normal and Reverse LCD. You may need to readjust after changing the reverse setting.

Manual Operation

MANUAL ROTATION This mode is like the simpler controllers where pressing the LEFT or the RIGHT button will cause the rotator to move to the left/CCW or the right/CW.

HEADING SET This mode you can dial in the desired heading with the HEADING SET knob then pressing the ROTATE button. The antenna will rotate to the selected heading and then stop. The rotator will normally stop within about 2 degrees of the desired heading once the COAST SET is set correctly. Fine tuning of the heading can be made with the manual buttons if desired. Holding in the ROTATE button for more than 2 seconds will set the reverse heading.

OFFSET The OFFSET can be used to shift the stop so the left stop is something other than 180 degrees in practice. The idea is to set the rotator to NORTH or some other convenient heading then shift the actual antenna heading (not the rotator) to the right a convenient amount like 20 or 45 degrees. After moving the antenna and tightening it down set the OFFSET to indicate the actual antenna heading. If the antenna was moved 20 degrees subtract 20 degrees from 360 which would be 340 and set the OFFSET calibration to 340 or whatever you actually moved the antenna to. This way you can turn from southwest of 180 degrees all the way around to southeast of 180 degrees. You are then not limited to 180 degrees as the stop point when rotating to the left. Note any time you go past the 180 degree right rotation point without any offset you will get an OVER message on the display which is OK. If you have set the OFFSET this message may show up earlier by the amount of offset, this is OK.

Computer Operation

The YRC-1 may be controlled from your computer via a USB Port. For USB communications plug a USB cable with the proper connector to the YRC-1 and then the other end into the computer USB port. First time installation may require installation of drivers for the USB IC. Windows 7 and 8 should automatically find the drivers for you. You may have to tell your computer to search for updates in the Windows Updates section of the Control Panel. You can manually find the drivers at the USB Chip manufacturer's web site: <http://www.ftdichip.com/Drivers/VCP.htm>. Choose the operating system and download the drivers. Follow the instructions that are included on the web page: <http://www.ftdichip.com/Support/Documents/InstallGuides.htm> for your operating system. Once the drivers are installed and the hardware is installed and ready to use you can then control the YRC-1 with any of the software available that will control the DCU-1. The DCU-1 DCU-2, DCU-3 and YRC-1 use the same command set. The USB chip is powered from the USB port so the port used must be able to supply power. There are also commands in the DCU-2, DCU-3 and YRC-1 to read the heading so programs such as Ham Radio Deluxe can receive feedback from the Controller and display the actual heading.

Software Control

Follow the instructions for the software package that you use to control the rotator for setup and operation. For example in Ham Radio Deluxe the Rotator control module asks for the Controller Type and the COM Port number. Other software vendors may also include the ability to directly control the YRC-1 from within a logging or rig control

program. Use the DCU-2, DCU-3 (or, YRC-1 or MDS RC-1 if in the list) and look for the COM port that the YRC-1 is plugged into. USB you should have the COM 1-4 list and then a higher number COM list of the devices plugged into the computer that act as virtual com ports. Choose the one that the YRC-1 is connected to. If you unplug the YRC-1 the USB com port should no longer be available. If you have chosen the correct com port then when instructed by the software the rotator should respond to the commands. If not then try one of the other com ports.

OPERATIONAL NOTES

When setting the heading occasionally you may notice the rotator seems to rotate in the wrong direction when controlled by the Heading Knob or by computer control. The

YRC-1 will try to turn in the direction that will be quickest when possible. It knows where the stops are and the offset and will choose the fastest direction.

There are 2 error messages that may be displayed on the YRC-1

MOTOR indicates that a command was issued to turn the rotator but no movement is indicated in a reasonable time. This may be due to something causing the rotator to bind and not turn like ice or tree limbs, or the motor or cable might be bad,.

CABLE indicates a problem with the cable, specifically the position sense lines on pins 2 and 3 may be open or high resistance. It also indicates that the cable may be unplugged. This error will also show 999 on the heading display.

USB COMMAND SET

There are 3 commands the YRC-1 is looking for that are sent as ASCII characters.

Command:	Result:
AP1***;	Sets Target Bearing in YRC-1 (***is a three digit number between 000 and 359)
AM1;	Starts rotation to Target Bearing
AI1;	Retrieves the current heading information.
;	Stops the rotator

The command is executed as soon as the semicolon is sent to the controller. The controller is not looking for a <CR> or <LF> command.

Figure 5. Command Set

The COM port is set to 4800 baud with no parity, 8 data bits, 1 stop bit and ASCII mode. This is usually shown as "4800,N,8,1".

You may wish to check with our Customer Service Dept. from time to time in order to obtain the latest firmware upgrades.

After a command is sent to the YRC-1, all other motor and brake operation is automatic.

Schematic Diagram

hygain YRC-1

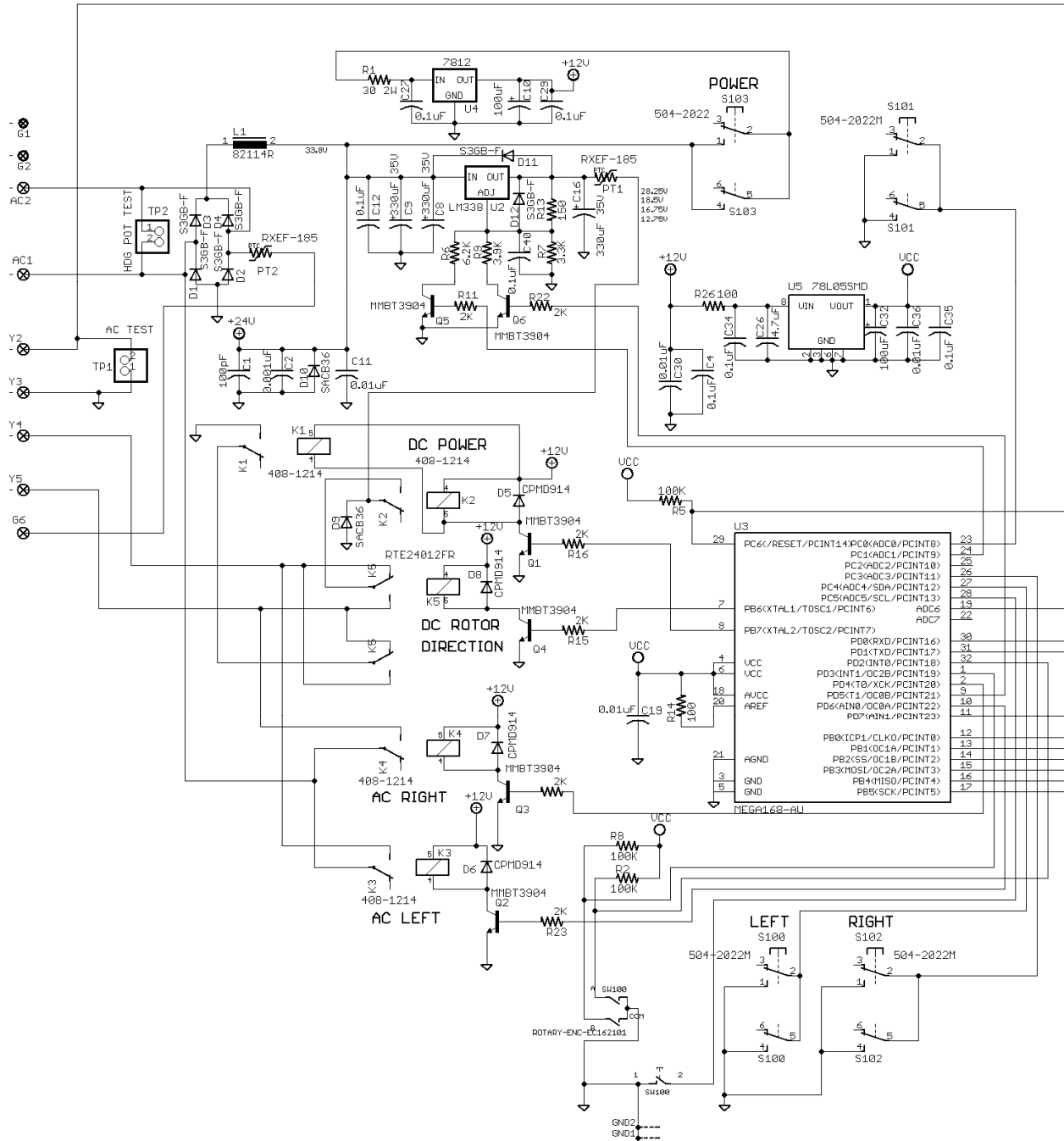

Figure 6A.

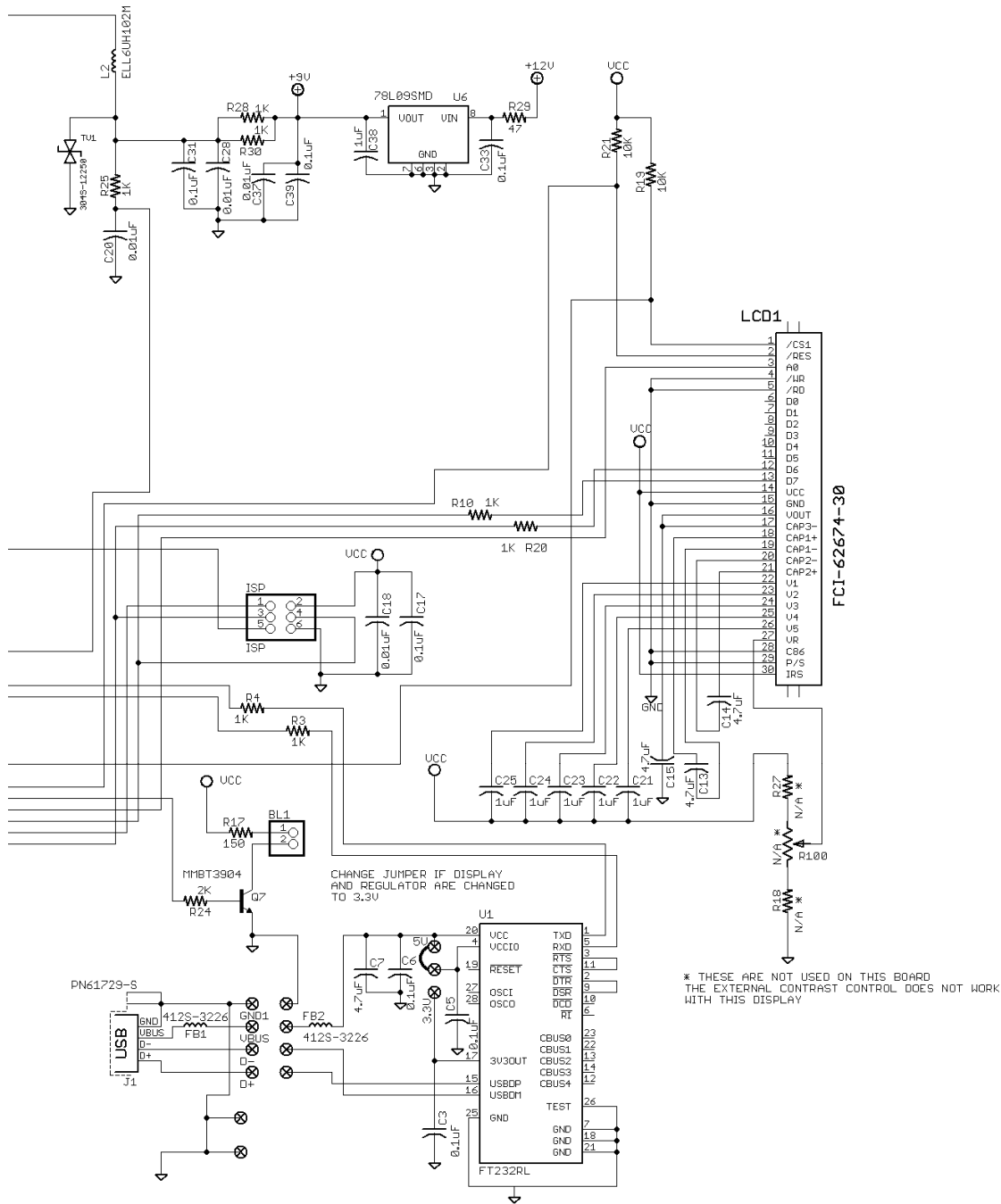

Figure 6B.

Block Diagram

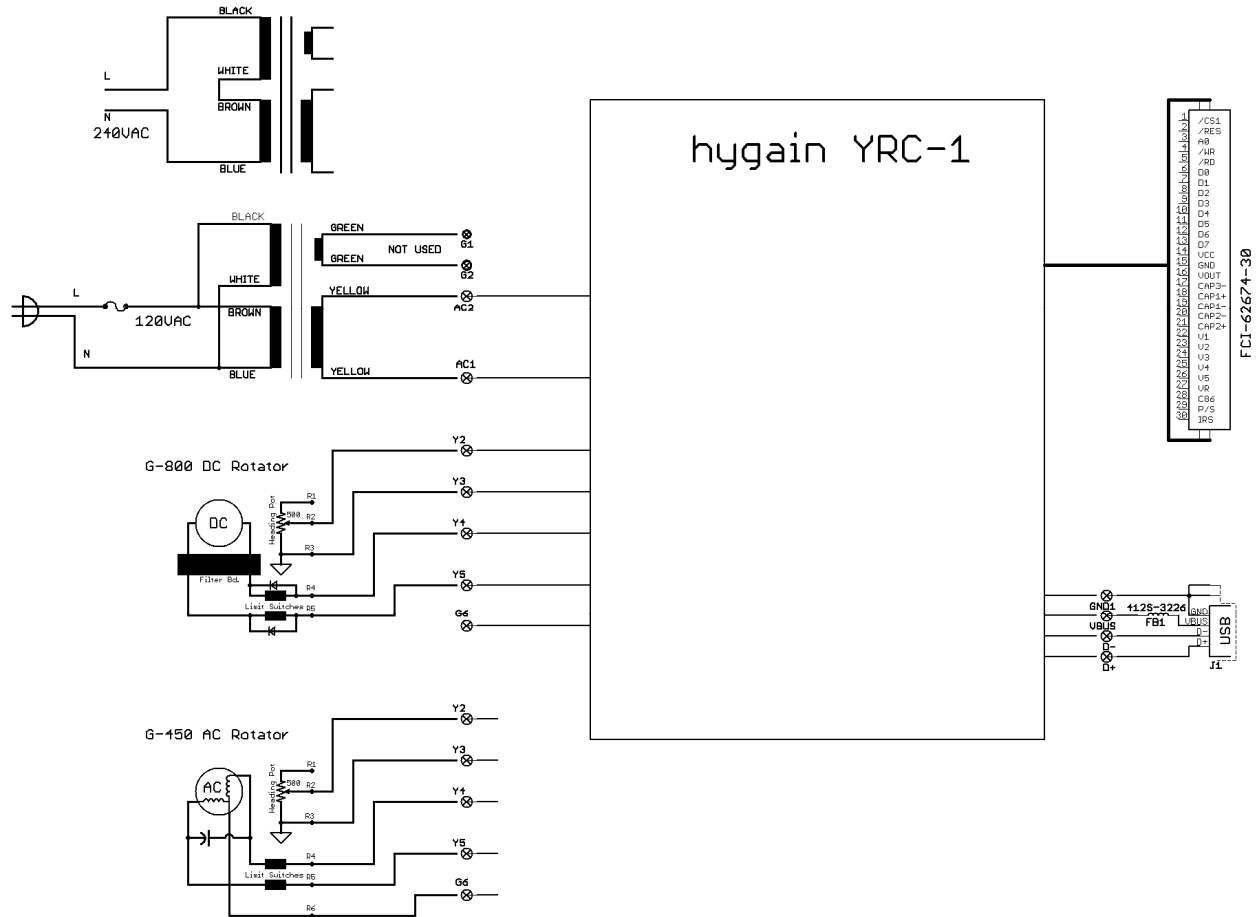

Figure 7. Schematic Block Diagram

For 120VAC operation the transformer is wired with the BLACK and BROWN wires connected to the fuse side terminal and the BLUE and WHITE wires connected to the Neutral terminal on the power connector.

For 240VAC operation the BLACK wire is connected to the fuse side terminal, the WHITE and BROWN wires are connected together and insulated, and the BLUE wire is connected to the Neutral terminal on the power connector.

The GREEN wires are not used on this application and are terminated on G1 and G2 which do not go anywhere.

How to Get Factory Service

If service is required, the unit must be packed and sent prepaid to:

hy-gain.

308 Industrial Park Rd.
Starkville, MS 39759 USA
Ph: (662) 323-9538 FAX: (662) 323-6551

For units that are in warranty, no charges will be made for any repair work required.

For out-of-warranty units, call the Warranty Service Department for prices.

The price includes rebuilding the unit, replacing all defective and/or worn parts, and return freight charges.

Hy-Gain reserves the right to change prices at its option. When returning items for repair, a check or money order for the repair charges must be included. Be sure to include your name, address, zip code, and telephone number. Also, give a brief description of the problem.

This information is believed correct, but no warranty is given or implied and no liability is assumed by as to its accuracy or completeness. Changes may be made from time to time so the user should verify all factors that may be critical. This information is not to be construed as to authorizing or advising use of any patented invention or any computer software.

12-MONTH LIMITED WARRANTY

Hy-Gain Warrants to the original owner of this product, if manufactured by Hy-Gain and purchased from an authorized dealer or directly from Hy-Gain to be free from defects in material and workmanship for a period of 12 months from date of purchase provided the following terms of this warranty are satisfied.

1. The purchaser must retain the dated proof-of-purchase (bill of sale, canceled check, credit card or money order receipt, etc.) describing the product to establish the validity of the warranty claim and submit the original or machine reproduction of such proof-of-purchase to Hy-Gain at the time of warranty service. Hy-Gain shall have the discretion to deny warranty without dated proof-of purchase. Any evidence of alteration, erasure, or forgery shall be cause to void any and all warranty terms immediately.
2. Hy-Gain agrees to repair or replace at Hy-Gain's option without charge to the original owner any defective product under warranty, provided the product is returned postage prepaid to Hy-Gain with a personal check, cashiers check, or money order for \$12.00 covering postage and handling.
3. Under no circumstances is Hy-Gain liable for consequential damages to person or property by the use of any products.
4. Out-of-warranty Service: Hy-Gain will repair any out-of-warranty product provided the unit is shipped prepaid. Unless other arrangements are made all repaired units will be shipped COD to the owner. Repair charges will be added to the COD fee.
5. This warranty is given in lieu of any other warranty expressed or implied.
6. Hy-Gain reserves the right to make changes or improvements in design or manufacture without incurring any obligation to install such changes upon any of the products previously manufactured.
7. All Hy-Gain products to be serviced in-warranty or out-of-warranty should be addressed to:

Hy-Gain
308 Industrial Park Road,
Starkville, Mississippi
39759, USA

and must be accompanied by a letter describing the problem in detail along with a copy of your dated proof-of-purchase.

8. This warranty gives you specific rights, and you may also have other rights which vary from state to state..

hy-gain[®]

**308 Industrial Park Rd.
Starkville, MS 39759 USA**

YRC-3 Digital Antenna
Rotator Controller
With Memories
For
Yaesu Rotators

Model YRC-3 Instruction Manual

hy-gain[®]

308 Industrial Park Road
Starkville, MS 39759 USA

Table of Contents

Precautions.....	4
YRC-3 Digital Antenna Rotator Controller.....	5
YRC-3 Digital Control Unit Specifications:	5
Installation.....	6
General Rotator Precautions.....	6
Wiring and Check-Out.....	6
NOTE:	7
Operation of YRC-3 Controller	9
Menu Functions	9
Menu Items.....	9
Menu Details	10
Manual Operation	11
MANUAL ROTATION.....	11
HEADING SET.....	11
Computer Operation	11
Software Control	12
OPERATIONAL NOTES	12
USB COMMAND SET	12
Driver Installation	13
Windows XP.....	13
Windows 7.....	13
Windows 8.....	14
Installing Unsigned Drivers in Windows 8.....	14
Schematic Diagram.....	16
Block Diagram	18
How to Get Factory Service.....	19
12-MONTH LIMITED WARRANTY	19

Yaesu is a registered trademark of Yaesu Musen Co., LTD. This product is not manufactured or serviced by Yaesu. Windows, Windows XP, Windows 7 and Windows 8 are registered trademarks of Microsoft Corp.

Precautions

Towers and antennas require caution during erection and placement! Extreme care must be taken during erection so that metal tower and antenna parts DO NOT contact power lines, even if the parts slip, rotate, retract, fall or fracture!

Antenna position mechanisms (towers and rotators) must be placed so that if they fail, the parts of the antenna system cannot contact power lines, be a hazard to individuals, or endanger property.

The YRC-3 Control Unit is not weatherproof and must be located in a house or other protected location. Connect a ground wire to the terminal on the back of the YRC-3.

Metal towers must be grounded properly at the tower location before the tower is erected. This is to minimize electrical hazard and reduces the possibility of lightning damage. DO NOT bury bare aluminum wires or stakes in the ground. Use copper or copper-clad ground stakes. The service entrance ground should be checked. The household electrical outlet should be the 3-prong type (grounded back to the service entrance). Follow all local building codes and the NFPA National Electric Codes for grounding.

The YRC-3 has been carefully designed and manufactured to give many years of trouble-free service when carefully and professionally installed. It consists of the strongest and best commercially available components. This product is manufactured in the U.S.A.

YRC-3 Digital Antenna Rotator Controller

The YRC-3 digital control unit features a Large LCD display indicating the beam heading, manual and computer controlled beam heading selection, and manual rotation controls.

Settings in memory include brake delay, rotator coast control, North and South center headings, adjustable sleep time, and call sign display.

The YRC-3 is designed as a replacement controller for both AC and DC Yaesu rotators and will work with the following Rotators:

- G-450
- G-650
- G-800/SA/DXA
- G-1000SA/DXA
- G-2800DXA

YRC-3 Digital Control Unit Specifications:

Size	4.125" x 8.5" x 9"	
Weight	6.25 lbs. (2.84 Kg)	
Voltage	120VAC or 240VAC (optional YRC-3X)	
Coast Delay	0-10 seconds	DEFAULT 0
Sleep Delay	1-255 minutes or continuous ON	DEFAULT 10

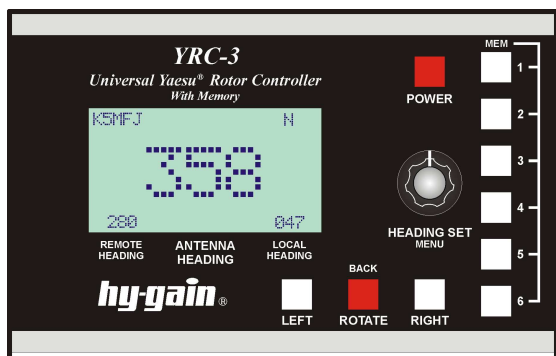

Figure 1. Front Panel

Front Panel Controls

- POWER Power ON/OFF
- LEFT Manually rotate left/CCW
- RIGHT Manually rotate right/CW
- HEADING SET/MENU Set the locally controlled antenna heading or bearing. Pushing in the "HEADING SET" selects any menu or the menu function selected or executes the menu function.
- ROTATE Instructs the controller to rotate the antenna to the locally set heading.
- MEM 1-6 Memory storage.

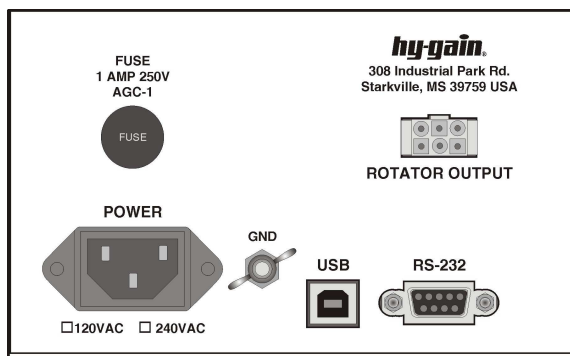

Figure 2. Back Panel

Back Panel Connections

- GROUND Chassis ground
- FUSE Protective fuse
- USB USB COM Port
- RS-232 RS-232 COM Port
- ROTATOR OUT Rotator connections
- POWER 120 VAC Input (240VAC Input optional)

Installation

The YRC-3 is designed to be a replacement controller for the standard Yaesu controllers and most likely a new install is not being done. Even so when installing or working on the rotator follow the Yaesu instructions for installation of the rotator to insure proper installation and operation.

General Rotator Precautions

1. Unbalanced weight: Weight should be as closely balanced as possible. Unbalanced weight in an antenna creates a bending moment of force which is concentrated on the mast at the point where it is clamped to the rotator.
2. Wind Pressure: Balanced wind pressure against the antenna system produces a bending force on the mast which can cause the same stresses as unbalanced weight. To minimize these forces, a thrust bearing should be used where possible, the antenna should be as close to the top of the tower as possible and the rotator shelf should be as low as possible
3. Unbalanced Wind: If the antenna has unequal wind areas and element spacing on each side of the mast attachment point, it could produce torque on the support mast. This is similar to the principle of a weather vane. If the unbalance is high enough or the wind velocity is high enough, this could prevent rotation or could damage the limit switches. To minimize this effect, the antenna should be designed for minimum mast torque or "torque compensators" added to produce minimum mast torque.
4. Mast Binding: If the antenna support mast binds within the tower due to ice accumulation or other reasons, this could prevent rotation

5. Extreme Cold: If the ambient temperature is at or below -30 degrees F, this could prevent rotation

The YRC-3 checks for rotator movement upon giving the command to rotate and if no movement is detected within 8 seconds, it will stop trying to rotate and the display will flash **MOTOR** above the main heading display.

Some of the older controllers used different connectors that have a different pin order but same numbers, follow the numbers. Wire using the diagram below. Newer rotor connectors have 7 pins. Pin 7 is not used.

Wiring and Check-Out

The YRC-3 is designed to be a replacement controller for the standard Yaesu controller. To this point the wiring should be as simple as unplugging from the old controller and plugging into the YRC-3.

The pins of the plastic connector and the rotator connector correspond, that is 1 to 1 and so on. Pin 7 on the metal rotator connector is not used. Refer to the Yaesu manual for more wiring details.

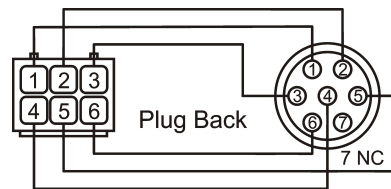

Figure 3. Connector Pinout

Pinout:

- | | |
|---|-----------------------------|
| 1 | Heading Pot High (not used) |
| 2 | Heading Pot Wiper |
| 3 | Heading Pot GND |
| 4 | Motor DC or AC Left |
| 5 | Motor DC or AC Right |
| 6 | Motor AC Common |

CAUTION:

Shorts between terminals or grounded leads may damage the rotator. Check the numbered pins on each connector with an Ohmmeter! Pin 1 is connected to pin 1, etc.

1. With the rotator sitting in the upright position (either on the bench or on the tower) and connected to the control unit by the 6-wire cable, plug the control unit power cord into a receptacle and turn it on.
2. Select the type of rotator you are using in the MODEL setup menu. G-450 and G-650 are **AC** models and most of the others like the G-800/SA/DXA, G-1000S/SA/DXA, and the G-2800DXA are **DC** models.
3. The YRC-3 display should look similar to the display shown in Figure 4. The numeric display in the center indicates the current bearing of your rotator. The numeric display in the lower right corner indicates the target bearing that is manually set. The numeric display in the lower left indicates target bearing that is computer set. The character display in the upper right corner indicates the compass heading in "NESW" format. The alphanumeric display in the upper left corner is where the call sign is displayed if programmed. If the center display reads a steady "999", disconnect your control cable and check the cable wiring with an ohmmeter. The resistance of the position sense pot measured between pin 1 and 3 should be 500 ohms plus the cable resistance. The reading between pins 2 and 3 should be somewhere between 0 and 500 ohms depending on the heading of the rotator. Anything much over 500 plus the resistance of the cable indicates a

possible problem Proceed if the cable checks OK. 999 also indicates that the cable may not be plugged in or the right stop has not been set.

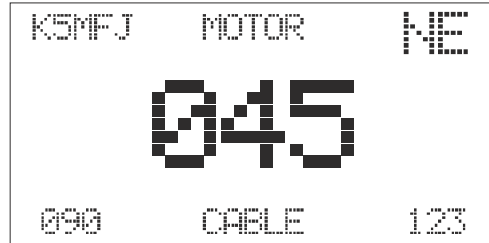

Figure 4. LCD Display

NOTE:

MOTOR is displayed when there is no indication of rotator movement and CABLE indicates a cable problem.

4. Test the rotation by pressing the LEFT or RIGHT buttons and verify that the rotator turns in the proper direction. During rotation the display will show the actual heading as it turns. If operation does not work as described, immediately unplug the unit from the AC line and check cable wiring!
5. Calibrate the rotation stops of the YRC-3. Calibration is done with the NORTHSTOP set to SOUTH. Yaesu Rotators will turn more than 360 degrees by about 90 degrees so you will pass 180 degrees when calibrating the right stop and will end up at 270 degrees for the right stop.
 - a. Rotate to the left manually by pressing the LEFT button until the rotator reaches the left mechanical stop then release.
 - b. Press and hold the MENU button until the menu is displayed.

- c. Turn the **Heading Set** knob if necessary to select "1.CALIBRATE" then press the **Heading set** knob in to select the function.
 - d. Turn the knob to select "1. LEFT STOP SOUTH" then press the **Heading Set** knob in to select. You may see the display change to 181 or 182 and the display will say **LEFT STOP**.
 - e. Next rotate the rotator to the right mechanical stop using the **RIGHT** button. The display may display the antenna heading of "999" when initially rotated to the right stop. This is OK as long as the left stop did not also display the antenna heading of "999".
 - f. Press and hold the **MENU** button until the menu is displayed.
 - g. Turn the **Heading Set** knob if necessary to select "1.CALIBRATE" then press the **Heading Set** knob in to select the function.
 - h. Turn the knob to select "2. RIGHT STOP SOUTH" then press the **Heading Set** knob in to select. You should see the display change to 270 and the display will say **RIGHT STOP**.
 - i. After setting the **LEFT** or **RIGHT** stop use the **LEFT** or **RIGHT** button to move the rotator off the stop. The controller requires it to be moved away from the stop the first time after calibration before it will turn using the memory positions, knob or computer.
6. After Calibration is complete the current bearing display should show a number between "000" and "359". Test the controls by twisting the **HEADING SET** knob. The **LOCAL HEADING** display should change. Using the knob, select a target bearing at least 30 degrees from the current bearing. Push the "ROTATE" button. The rotator should turn to the heading plus or minus 2 or 3 degrees.
 7. If this is a new installation, or you are testing the rotator on the bench rotate the system to the center of rotation. You are now ready to install the rotator system in your tower or on your mast. Refer to the instructions in your rotator manual for complete installation information.

Operation of YRC-3 Controller

Menu Functions

Menu Items

1. CALIBRATE
 - a. 1. LEFT STOP SOUTH
 - b. 2. RIGHT STOP SOUTH
2. OFFSET
 - a. Encoder sets the offset from the original setup. Dial in the amount and press the encoder to select the change
 - b. 0 to 360 degrees
3. CALLSIGN
 - a. Turn the encoder to display the character then press the encoder to select and advance to the next character. Press a second time to save the call sign.
4. DEFAULTS
 - a. Resets back to original settings. Select YES or NO to reset.
 - b. All memory settings are retained till it is set back to Default.
5. NORTHSTOP
 - a. Default is NO
 - b. Use the encoder to select YES or NO then press the encoder.
6. SLEEP DELAY
 - a. Default is 10 minutes
 - b. Set 1 to 255 minutes or 0 for always on.
7. COAST SET
 - a. Default 0
 - b. Sets the heading that will turn off the motor before it reaches the heading so it will coast to that heading. 0 to 10 degrees.
8. REVERSE LCD
 - a. Default is NORMAL where the characters are light and the background is blue/dark.
 - b. REVERSE is blue/dark characters and light background.
9. MODEL TYPE
 - a. To select the type of rotator
 - b. Set to either DC or AC
10. CONTRAST
 - a. Set for best contrast. Range is 1 to 32 with a setting around 20 to 25 for normal contrast.
11. EXIT
 - a. To leave menu mode without waiting for it to time out and return to regular operation.

Menu Details

OFFSET is used to compensate for any mechanical errors that may be in the antenna heading. For example: if the antenna is set to 360 degrees and it is found to be actually pointing at 355 degrees, the **OFFSET** can be set to compensate for this error by selecting the value that will show the actual heading.

COAST SET is used to compensate for overshoot of the heading. The inertia of large mass antennas will cause them to pass the desired heading and setting this adjustment will help by turning off the motor and let the antenna coast to the desired spot. This will have to be tried experimentally to find the best setting for your antenna.

CALLSIGN is used to set up the call sign display on the screen if desired. Select the menu function then enter the characters by turning the **Heading Set** knob to the desired character then press the knob in to allow selection of the next character. Once all the characters have been entered press the knob again to exit this mode.

NORTHSTOP Some of the older Yaesu rotators have the mechanical stop at North instead of South. For those rotators you will need to invoke this function. Calibrate the rotator with the YRC-3 set to **SOUTH** stop with the calibration instructions above then set the **NORTHSTOP** to **NORTH** by turning the **Heading Set** knob to select **YES** then press the knob in.

In some cases you may want your antenna centered toward the south with the stops at the north. If this is the case put up the antenna pointed to the **SOUTH** and once installed and ready, select this function and turn the **Heading Set** knob to select **YES** then press the knob in.

SLEEP DELAY is used to put the control into a sleep mode where the LCD back light turns off and the microprocessor goes into a low power state. It will wake back up with the press of any button or any command on the COM port. Selecting this menu will allow you to set the time from 0 to 255 in minutes. 0 is always on. When the unit goes to sleep the back light will turn off. Pushing any button, turning the **Heading Set**, or a computer command will wake it up. Programs that query for the heading on a timed basis will keep the controller awake.

REVERSE LCD changes the characters and background from dark blue background and white letters to a white background and dark letters as viewed from straight on. When viewed from a side angle or above the display at the display viewing limits, the characters in normal mode may look dark with a light background. To select the reverse mode select this menu item then turn the **Heading Set** knob to say **YES** for reverse or **NO** for normal then press the knob to select.

MODEL TYPE sets the YRC-3 to control either the DC Rotators like the G-800 and G-1000 or AC like the G-450 Rotators.

CONTRAST adjusts the contrast for best viewing. To adjust select this menu item and turn the heading control for best contrast. The range is 1 to 32 with a setting around 25 near optimum depending on the display batch received. The contrast setting may or may not be the same setting for best contrast between Normal and Reverse LCD. You may need to readjust after changing the reverse setting.

Manual Operation

MANUAL ROTATION This mode is like the simpler controllers where pressing the **LEFT** or the **RIGHT** button will cause the rotator to move to the Left/CCW or the Right/CW.

HEADING SET This mode you can dial in the desired heading with the **HEADING SET** knob then pressing the **ROTATE** button. The antenna will rotate to the selected heading and then stop. The rotator will normally stop within about 2 degrees of the desired heading once the **COAST SET** is set correctly. Fine tuning of the heading can be made with the manual buttons if desired. Holding in the **ROTATE** button for more than 2 seconds will set the reverse heading.

OFFSET The **OFFSET** can be used to shift the stop so the left stop is something other than 180 degrees in practice. The idea is to set the rotator to **NORTH** or some other convenient heading then shift the actual antenna heading (not the rotator) to the right a convenient amount like 20 or 45 degrees. After moving the antenna and tightening it down set the **OFFSET** to indicate the actual antenna heading. If the antenna was moved 20 degrees subtract 20 degrees from 360 which would be 340 and set the **OFFSET** calibration to 340 or whatever you actually moved the antenna to. This way you can turn from southwest of 180 degrees all the way around to southeast of 180 degrees. You are then not limited to 180 degrees as the stop point when rotating to the right. Note any time you go past the 180 degree right rotation point without any offset you will get an **OVER** message on the display which is OK. If you have set the **OFFSET** this message may show up earlier by the amount of offset, this is OK.

MEMORY The **MEMORY** positions 1-6 can hold your favorite beam headings. To save

the heading, rotate the antenna to the desired heading, then hold the memory button in until the display shows **PROG** on the screen. To recall a heading press the button the heading was stored in. The rotator will turn to the programmed heading.

Computer Operation

The YRC-3 may be controlled from your computer via an RS232 port or a USB Port. For USB communications plug a USB cable with the proper connector to the YRC-3 and then the other end into the computer USB port.

First time installation may require installation of drivers for the USB IC. Download the drivers from the Hy-Gain web site in the section for the YRC-3 and store them in a place easy to find. Plug in the YRC-3 and turn it on. When the display screen is showing the heading the USB port will tell the computer it is active. The computer should show a message that it is installing the hardware then open a box asking for the driver software to be installed See the section on Driver Installation for more details on the drivers.

Once the drivers are installed and the hardware is installed and ready to use you can then control the YRC-3 with any of the software available that will control the DCU-1. The DCU-1 DCU-2, DCU-3, YRC-1 and YRC-3 use the same command set. The USB chip is powered from the USB port so the port used must be able to supply power. There are also commands in the DCU-2, DCU-3, YRC-1 and YRC-3 to read the heading so programs such as Ham Radio Deluxe can receive feedback from the Controller and display the actual heading.

Software Control

Follow the instructions for the software package that you use to control the rotator for setup and operation. For example in Ham Radio Deluxe the Rotator control module asks for the Controller Type and the COM Port number. Other software vendors may also include the ability to directly control the YRC-3 from within a logging or rig control program. Use the DCU-2, DCU-3, YRC-1 (or, YRC-3 or MDS RC-1 if in the list) and look for the COM port that the YRC-3 is plugged into. USB you should have the COM 1-4 list and then a higher number COM list of the devices plugged into the computer that act as virtual com ports. Choose the one that the YRC-3 is connected to. If you unplug the YRC-3 the USB com port should no longer be available. If you have chosen the correct com port then when instructed by the software the rotator should respond to the commands. If not then try one of the other com ports.

USB COMMAND SET

There are four commands the YRC-3 is looking for that are sent as ASCII characters.

Command:	Result:
AP1***;	Sets Target Bearing in YRC-3 (***) is a three digit number between 000 and 359)
AM1;	Starts rotation to Target Bearing
AI1;	Retrieves the current heading information.
;	Stops the rotator

The command is executed as soon as the semicolon is sent to the controller. The controller is not looking for a <CR> or <LF> command.

Figure 5. Command Set

OPERATIONAL NOTES

When setting the heading occasionally you may notice the rotator seems to rotate in the wrong direction when controlled by the Heading Knob or by computer control. The YRC-3 will try to turn in the direction that will be quickest when possible. It knows where the stops are and the offset and will choose the fastest direction.

There are 2 error messages that may be displayed on the YRC-3

MOTOR indicates that a command was issued to turn the rotator but no movement is indicated in a reasonable time. This may be due to something causing the rotator to bind and not turn like ice or tree limbs, or the motor or cable might be bad,.

CABLE indicates a problem with the cable, specifically the position sense lines on pins 2 and 3 may be open or high resistance. It also indicates that the cable may be unplugged. This error will also show 999 on the heading display.

The COM port is set to 4800 baud with no parity, 8 data bits, 1 stop bit and ASCII mode. This is usually shown as "4800,N,8,1".

After a command is sent to the YRC-3, all other motor and brake operation is automatic.

You may wish to check with our Customer Service Dept. or the Hy-Gain web site from time to time in order to obtain the latest firmware upgrades.

Driver Installation

These drivers are for Windows operating systems only.

Download the drivers from the Hy-Gain web site and save them in a convenient spot to retrieve them during install.

Different operating systems will have differing methods of install and may be somewhat involved. If you are not comfortable in installing the drivers then find local help with the install. Hy-Gain technicians are not computer technicians and cannot help with computer driver install issues.

Windows XP

1. Plug the YRC-3 USB cable in. The Plug and Play routine for installing the device should display a message that it found a new device and then open up a dialog box asking if you want to install the drivers. It is possible that the computer knows where the drivers are and install them automatically
2. In the first dialog box select "No not this time"
3. In the second dialog box select "Install from specific location"

4. In the third dialog box select Search for the best driver" and also select "Include this location in the search" and click on the Browse button to browse to the location of the drivers. Then click NEXT.
5. A message may come up saying the drivers have not passed Windows testing to verify compatibility. Click on "Install Anyway"
6. The drivers should install and a message that the device is ready to use should appear.

Windows 7

1. Plug in the YRC-3 to the USB port. The plug and play routine should find the device. If the drivers are available through Microsoft then it should install and come up with a message that it is ready to use.
2. If the drivers are not available, then an error message should come up saying that the device has problems. If this is the case then continue with these install instructions.
3. Open the *Control Panel* and in the *Devices and Printers* application under **Unspecified** section a device "RC1 USB Serial Port" with a yellow triangle and exclamation point in it should be listed.
4. Double click on the RC1 device and select the hardware tab.
5. Click on the Properties button.
6. Click on the Update Driver button.
7. In the "Search for the driver software in this location" click on the Browse button and browse to the location of the driver and select it. Then click Next.

8. A message may come up saying the drivers have not passed Windows testing to verify compatibility. Click on “Install Anyway”
9. The driver should install and a message that the device is ready to use.

Windows 8

1. Plug in the YRC-3 to the USB port. The plug and play routine should find the device. If the drivers are available through Microsoft then it should install and come up with a message that it is ready to use.
2. **To manually install** the drivers swipe in from the right edge of the screen, and then tap or click **Search**.
3. Enter **Device Manager** in the search box, and tap or click **Device Manager**.
4. In the list of hardware categories, double-tap or double-click the category your device is in and then double-tap or double-click the device you want.
5. If the driver is signed, the driver will install and be ready for use. If the driver is unsigned, a message should come up saying the drivers have not passed Windows testing to verify compatibility. *It will not install except by going through the commands turning off the protection allowing the driver to be installed.*

Installing Unsigned Drivers in Windows 8

Driver signature enforcement is a security feature that makes it much more difficult for average users to install malicious hardware drivers on their systems. If a driver is not properly signed, or it was signed with a signature that has been revoked because it

was used for malicious purposes, Windows 8 will not allow users to install it in the normal way. The YRC-3 drivers obtained from Hy-Gain are safe and do not contain any malicious code.

Disabling the driver signature check may be necessary for installing the YRC-3 hardware drivers that may not be signed.

Note disabling the driver signature check is very involved and if you are not comfortable going through the steps find someone that can help with the driver install. Hy-Gain technicians are not computer technicians and cannot help with computer driver install issues.

1. Open the **Settings** charm.
2. Select the “**Change PC Settings**” option at the bottom of the **Settings** charm.
3. In the **PC Settings** application select the **General** category.
4. Scroll down and click the **Restart Now** button under **Advanced Startup**. Your computer will reboot.
5. When the “**Choose An Option**” screen appears, click or tap the **Troubleshoot** tile.
6. Next, click or tap the **Advanced Options** tile.
7. Select the **Startup Settings** tile on the **Advanced Options** screen.
8. Click the **Restart** button on the **Startup Settings** screen to reboot your computer again.
9. On the **Startup Settings** screen, tap the **F7** or **7** key on your keyboard to select the “**Disable driver signature enforcement**” option.
10. Windows 8 will immediately boot to its typical lock screen. Sign into Windows 8 as you normally would

and everything will look the same, except Windows will no longer demand driver signatures until you next reboot.

11. You can now install YRC-3 USB driver as you would on previous versions of Windows. Windows will alert you if you try to install a driver that is not properly signed, but you will see an “Install this driver software anyway” option you can choose.
12. When you are done installing the unsigned driver, reboot your computer. Windows will use the YRC-3 driver and any other unsigned drivers you have already loaded. The Driver Signature Enforcement will be turned back on for any future driver installs.

Schematic Diagram

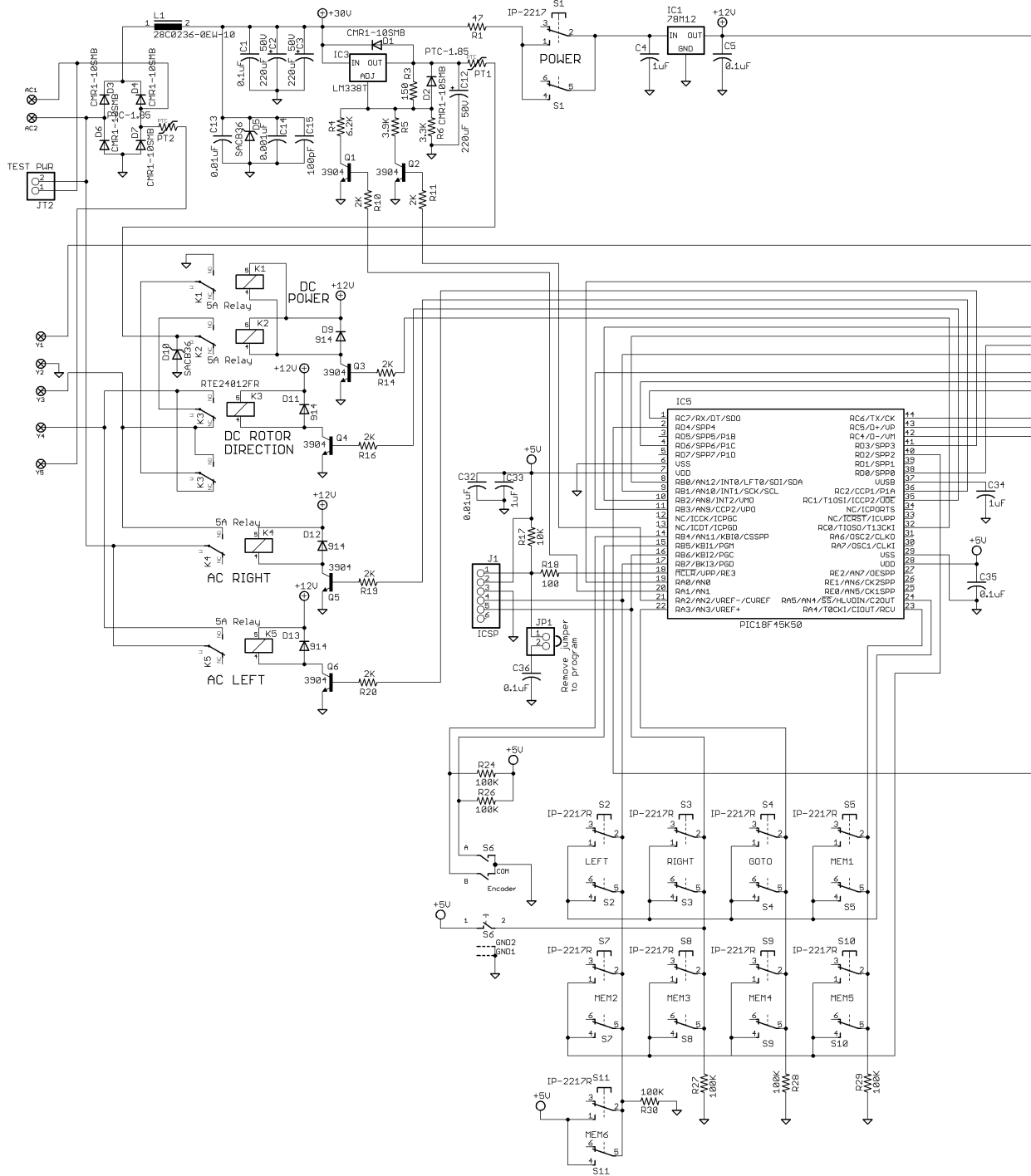

Figure 6A.

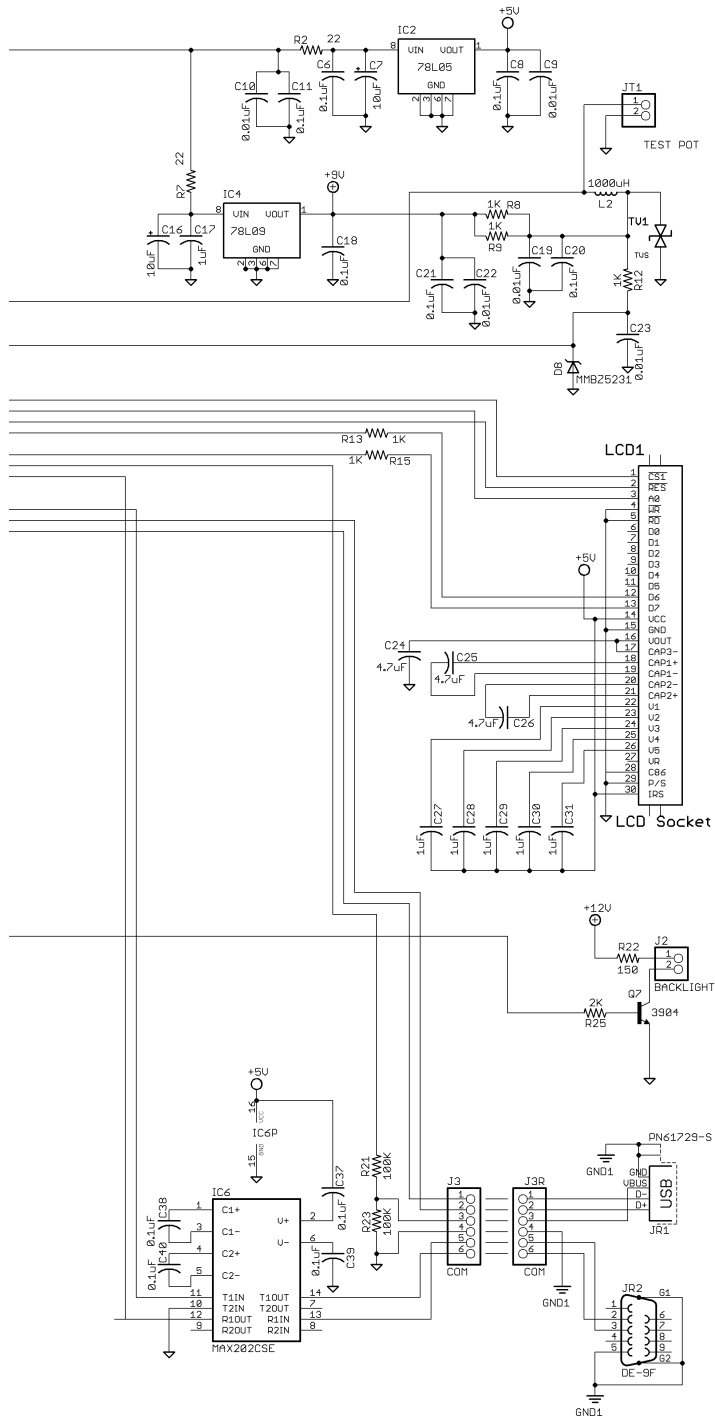

Figure 6B.

Block Diagram

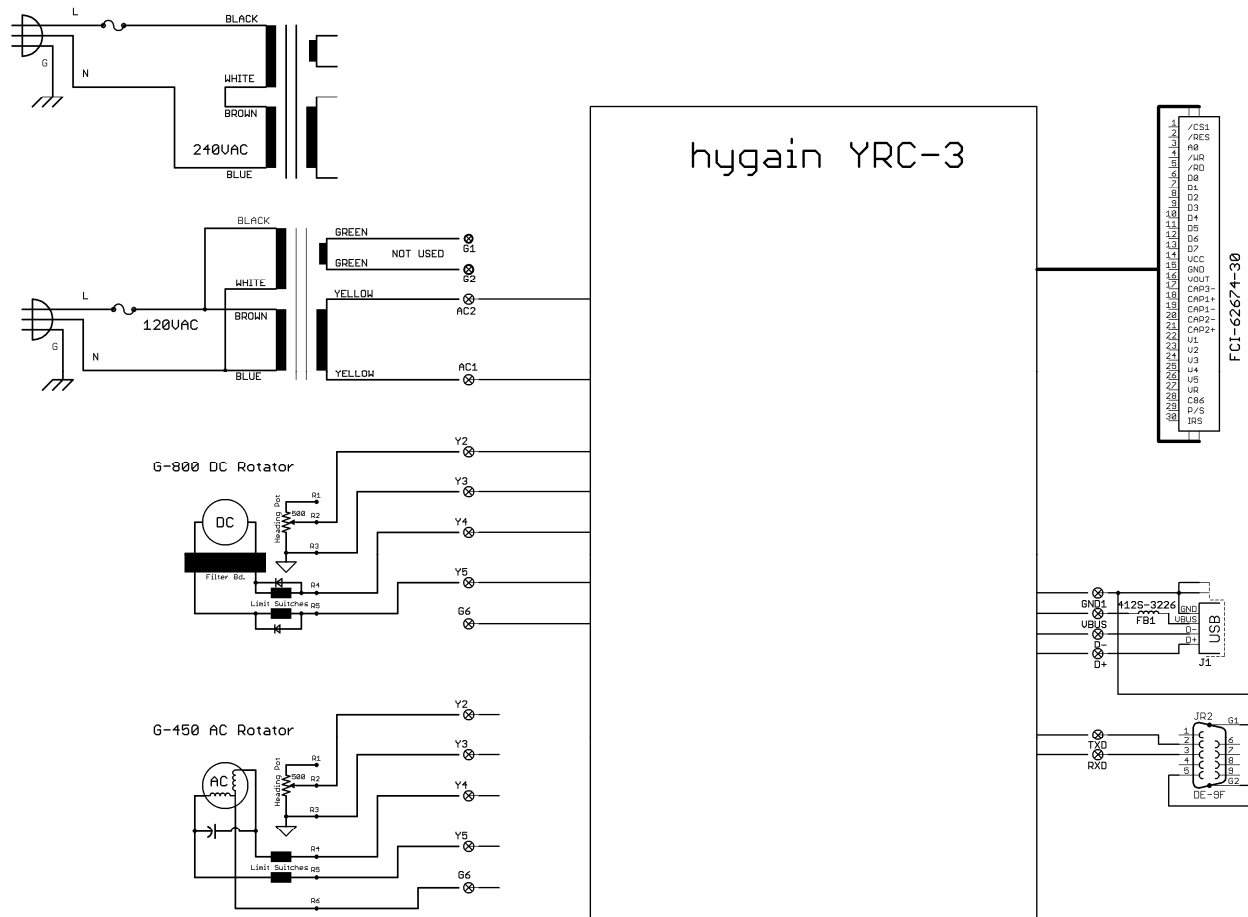

Figure 7. Schematic Block Diagram

For 120VAC operation the transformer is wired with the BLACK and BROWN wires connected to the fuse side terminal and the BLUE and WHITE wires connected to the Neutral terminal on the power connector.

For 240VAC operation the BLACK wire is connected to the fuse side terminal, the WHITE and BROWN wires are connected together and insulated, and the BLUE wire is connected to the Neutral terminal on the power connector.

The transformer GREEN wires are not used on this application and are terminated on G1 and G2 which do not go anywhere.

How to Get Factory Service

If service is required, the unit must be packed and sent prepaid to:

hy-gain.

308 Industrial Park Rd.
Starkville, MS 39759 USA
Ph: (662) 323-9538 FAX: (662) 323-6551

For units that are in warranty, no charges will be made for any repair work required.

For out-of-warranty units, call the Service Department for prices.

The price includes rebuilding the unit, replacing all defective and/or worn parts, and return freight charges.

Hy-Gain reserves the right to change prices at its option. When returning items for repair, a check or money order for the repair charges must be included. Be sure to include your name, address, zip code, and telephone number. Also, give a brief description of the problem.

This information is believed correct, but no warranty is given or implied and no liability is assumed by as to its accuracy or completeness. Changes may be made from time to time so the user should verify all factors that may be critical. This information is not to be construed as to authorizing or advising use of any patented invention or any computer software.

12-MONTH LIMITED WARRANTY

Hy-Gain Warrants to the original owner of this product, if manufactured by Hy-Gain and purchased from an authorized dealer or directly from Hy-Gain to be free from defects in material and workmanship for a period of 12 months from date of purchase provided the following terms of this warranty are satisfied.

1. The purchaser must retain the dated proof-of-purchase (bill of sale, canceled check, credit card or money order receipt, etc.) describing the product to establish the validity of the warranty claim and submit the original or machine reproduction of such proof-of-purchase to Hy-Gain at the time of warranty service. Hy-Gain shall have the discretion to deny warranty without dated proof-of purchase. Any evidence of alteration, erasure, or forgery shall be cause to void any and all warranty terms immediately.
2. Hy-Gain agrees to repair or replace at Hy-Gain's option without charge to the original owner any defective product under warranty, provided the product is returned postage prepaid to Hy-Gain with a personal check, cashiers check, or money order for \$16.00 covering postage and handling.
3. Under no circumstances is Hy-Gain liable for consequential damages to person or property by the use of any products.
4. Out-of-warranty Service: Hy-Gain will repair any out-of-warranty product provided the unit is shipped prepaid. Unless other arrangements are made all repaired units will be shipped COD to the owner. Repair charges will be added to the COD fee.
5. This warranty is given in lieu of any other warranty expressed or implied.
6. Hy-Gain reserves the right to make changes or improvements in design or manufacture without incurring any obligation to install such changes upon any of the products previously manufactured.
7. All Hy-Gain products to be serviced in-warranty or out-of-warranty should be addressed to:

Hy-Gain
308 Industrial Park Road,
Starkville, Mississippi
39759, USA

and must be accompanied by a letter describing the problem in detail along with a copy of your dated proof-of-purchase.

8. This warranty gives you specific rights, and you may also have other rights which vary from state to state..

hy-gain[®]

**308 Industrial Park Rd.
Starkville, MS 39759 USA**